

# DRYWALL FRAME KIT

---

## Installation Instructions

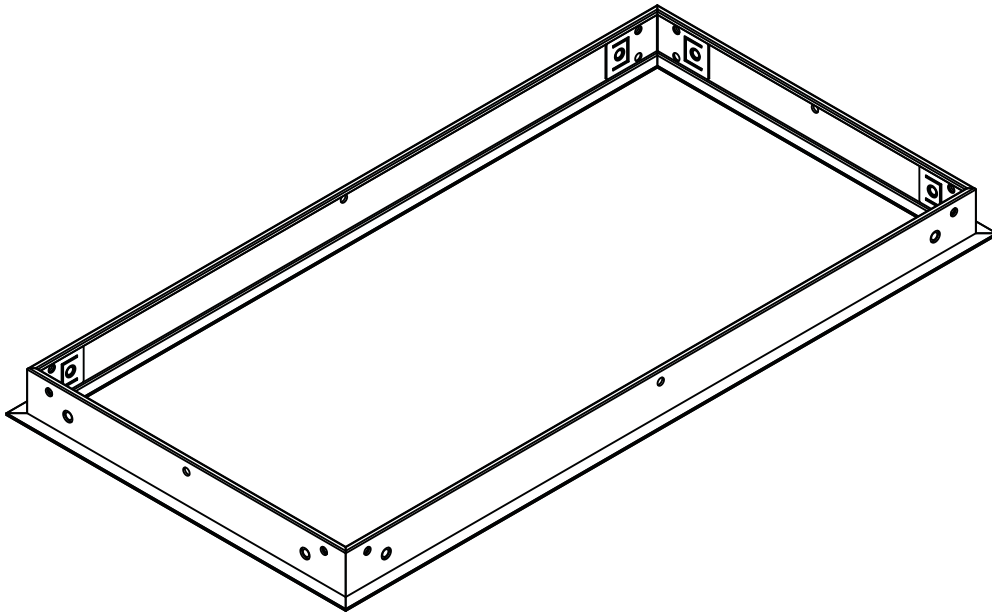
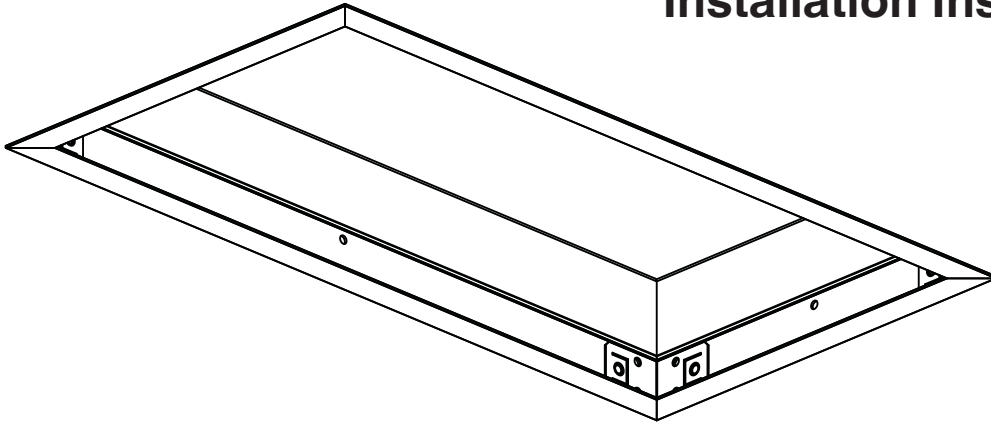

580 Mayer Street - Building # 7 - Bridgeville, PA 15017 USA

Phone: 1.412.206.0106 - Fax: 1.412.206.0146

1. Assemble the drywall frame kit with corner brackets.

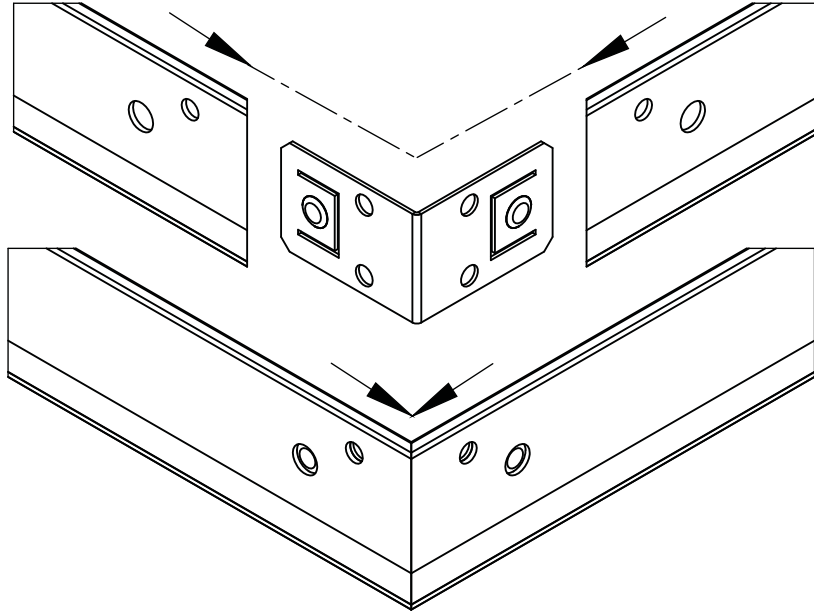

2. Opening Size: See chart on following page. (Do not exceed opening size by more than 1/8-in.)

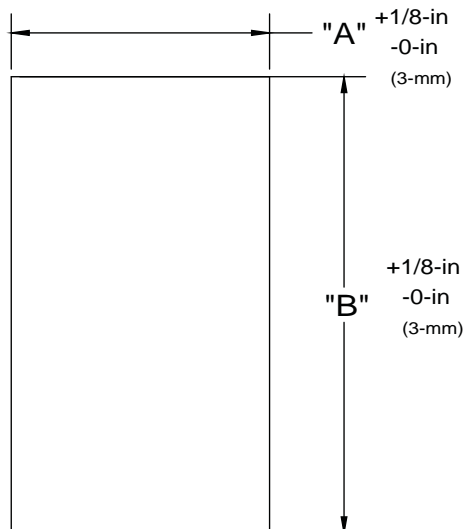

PART NUMBER	DESCRIPTION	OVERALL FRAME DIMENSIONS	CUTOUT A	CUTOUT B
016-229	1-ft X 2-ft IMPERIAL PANEL	13.06-in X 25.06-in	12 9/32-in	24 9/32-in
016-228	2-ft X 2-ft IMPERIAL PANEL	25.06-in X 25.06-in	24 9/32-in	24 9/32-in
016-347	300-mm X 600-mm METRIC PANEL	330-mm X 630-mm	310-mm	610-mm
016-348	600-mm X 600-mm METRIC PANEL	630-mm X 630-mm	610-mm	610-mm
016-354	150-mm X 600-mm METRIC PANEL	180-mm X 630-mm	160-mm	610-mm
016-355	6-in X 2-ft IMPERIAL PANEL	7.06-in X 25.06-in	6 9/32-in	24 9/32-in
016-356	150-mm X 1200-mm METRIC PANEL	180-mm X 1210-mm	160-mm	1210-mm
016-357	6-in X 4-ft IMPERIAL PANEL	7.06-in X 49.06-in	6 9/32-in	48 9/32-in

### 3. Frame out ceiling opening.

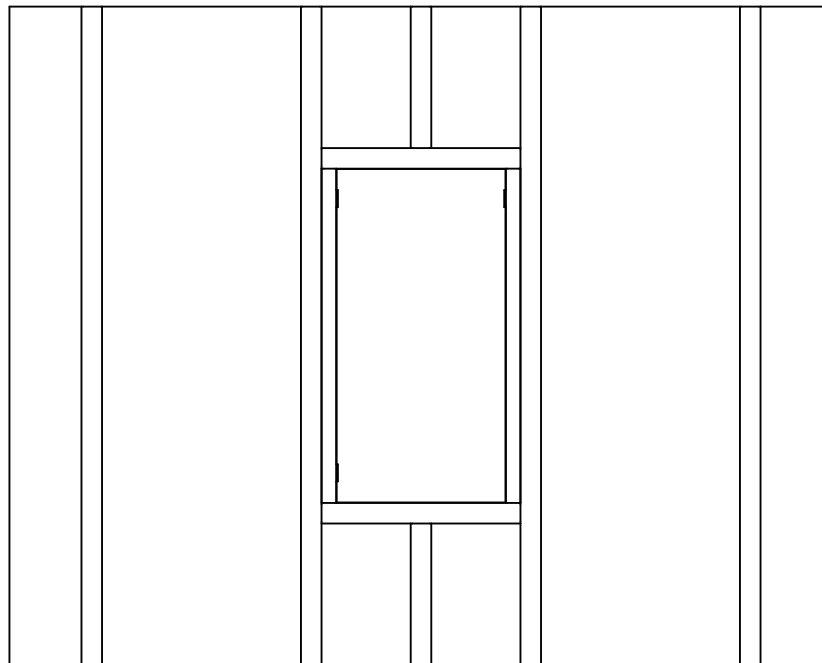



4. Connect wiring below drywall. Install fixture in ceiling and set on top of framing.

*\*Note: electrical power connections must be made prior to installing the fixture unless the fixture top will remain accessible.*

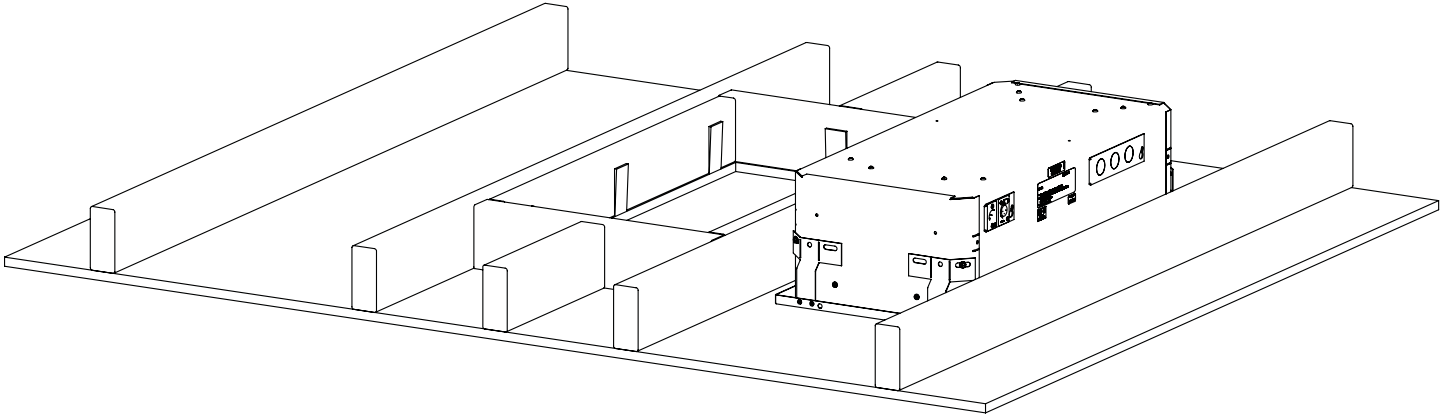

5. Install drywall frame kit.

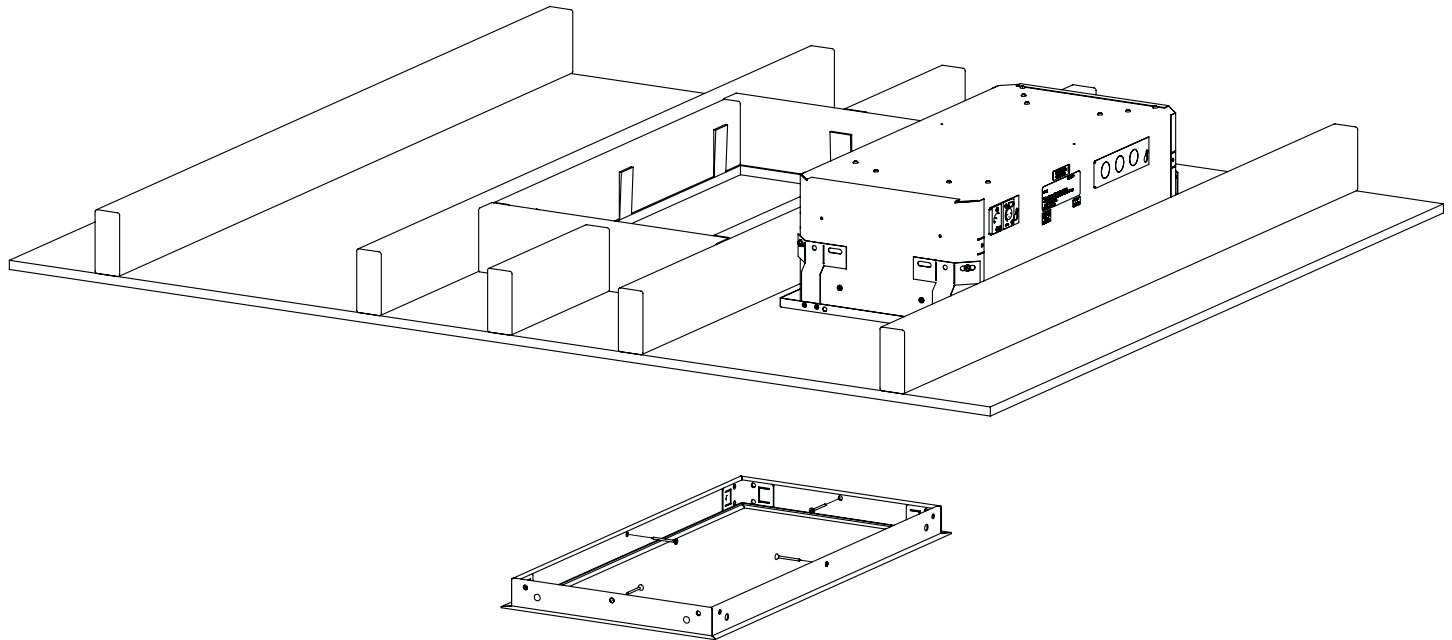

Screw (supplied by others) or nail (supplied by others) frame securely into side framing members. This must be sufficient to support the combined weight of installed fixture and frame kit. *Note: Refer to datasheet of the fixture for weight.*

6. Use wood shims to remove any slop.

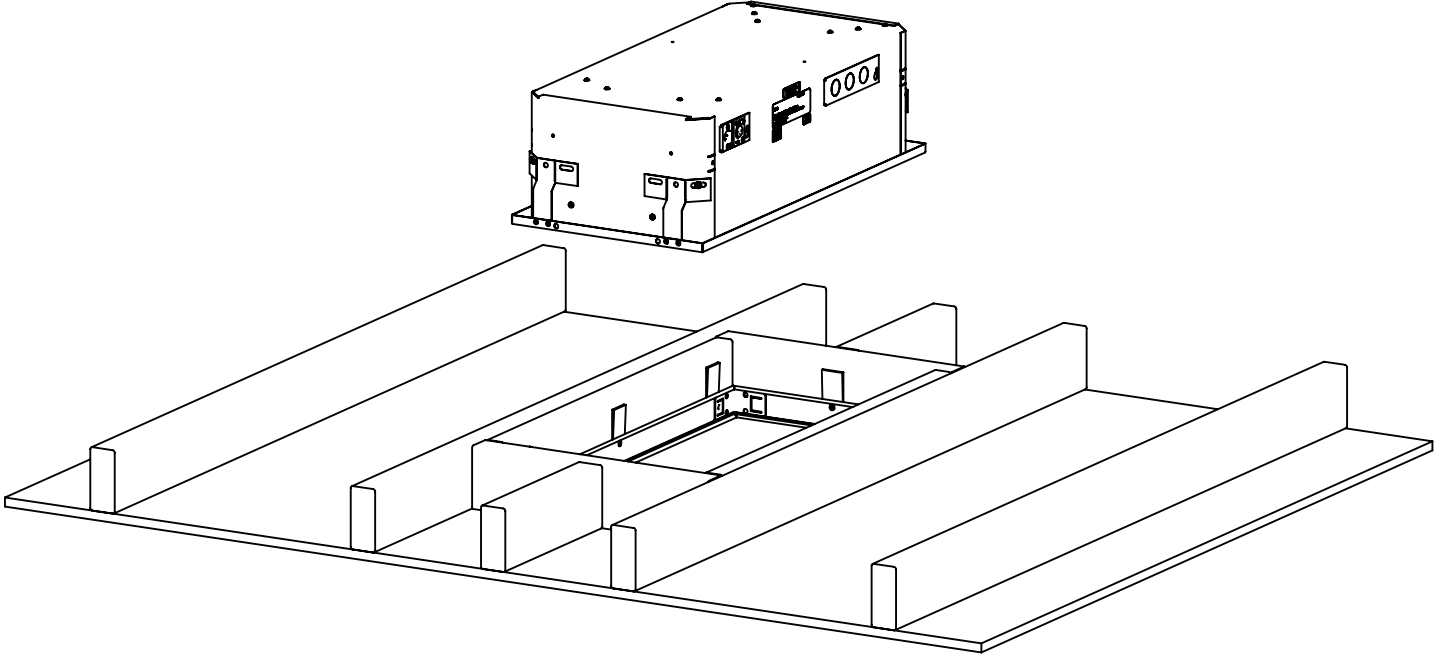

7. Lower fixture into drywall frame kit.

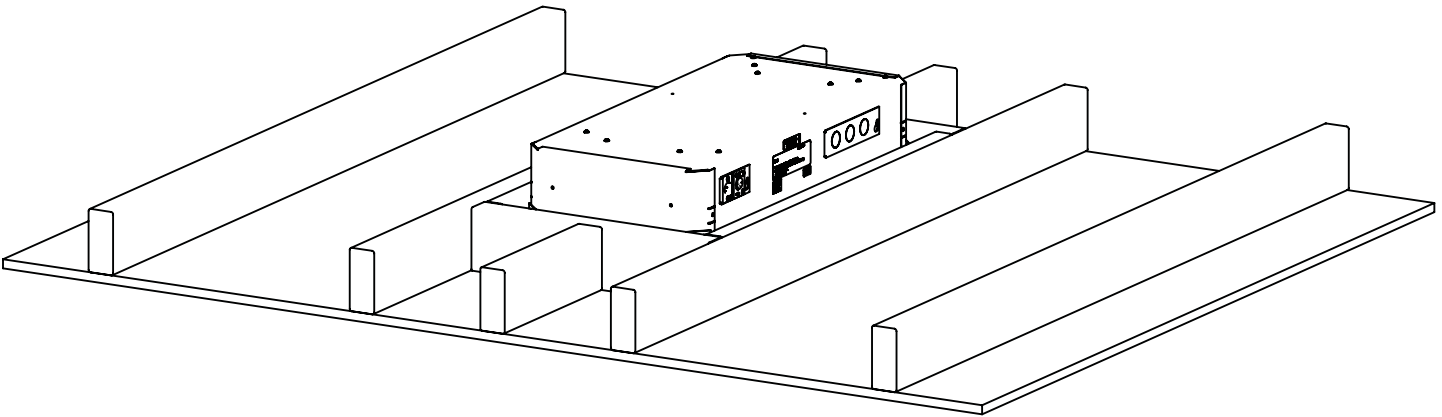

Drywall Frame Kit Nominal Sizes



**6-in x 4-ft**  
(150-mm x 1200-mm)



**6-in x 2-ft**  
(150-mm x 600-mm)

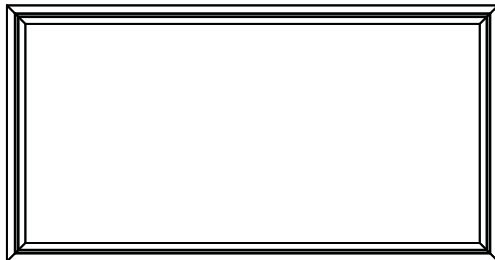

**1-ft x 2-ft**  
(300-mm x 600-mm)

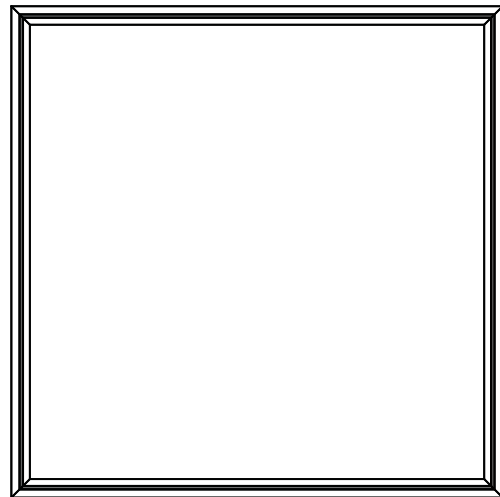

**2-ft x 2-ft**  
(600-mm x 600-mm)



**brightline**<sup>®</sup>  
Evolutionary Lighting Systems



## WARRANTY

**Brightline** guarantees all its products to be free from defects in materials and workmanship for a period of one (1) year from the date of shipment.

## PROCEDURES

If any product is found to be unsatisfactory under this warranty, the buyer must notify **Brightline** immediately. Once a course of action has been determined, if it is necessary to return the product to **Brightline**, a Return Authorization (RA) will be issued. Ship the product directly to **Brightline**, 580 Mayer Street, Building #7, Bridgeville, PA 15017 USA. The RA number should be marked on the shipping carton. The unit will be replaced or put into proper operating condition, free of all charges. The correction of any defects through repair or replacement by **Brightline** shall constitute fulfillment of all obligations and liability of **Brightline** to the buyer under this warranty and the contract of sale.

## DISCLAIMERS

**Brightline** is not responsible for damage to its products caused by improper installation, maintenance, or use, by improper electrical hookups, or by unauthorized repairs.

Failure to notify **Brightline** of unsatisfactory operation or any improper or unauthorized installation, maintenance, use, repairs, or adjustments shall terminate the warranty and **Brightline** shall have no further responsibility under the warranty.

**Brightline** shall not be liable for special or consequential damages in any claim, action, suit, or proceeding arising under this warranty or contract of sale, nor shall **Brightline** be liable for claims for labor, loss of profits or goodwill, repairs, or other expenses incidental to replacement. **Brightline** makes no other warranty of any kind whatsoever, expressed or implied, and all implied warranties of merchantability and fitness for a particular purpose that exceed the obligation specifically described in this warranty are hereby disclaimed by **Brightline** and excluded from this agreement.

All shipments, unless otherwise noted, are F.O.B. factory.

The customer is advised to inspect for shipping damage, apparent and/or hidden. If detected, notify the transportation company and file your claim.

580 Mayer Street, Building #7, Bridgeville, PA 15017 USA · phone 1.412.206.0106 · fax 1.412.206.0146  
[www.brightlines.com](http://www.brightlines.com)

580 Mayer Street - Building # 7 - Bridgeville, PA 15017 USA

Phone: 1.412.206.0106 - Fax: 1.412.206.0146



© 2016 Brightline LP All Rights Reserved

*Specifications are subject to change without notice.*

















**brightline**<sup>®</sup>  
*Evolutionary Lighting Systems*

---

580 Mayer Street - Building # 7 - Bridgeville, PA 15017 USA

Phone: 1.412.206.0106 - Fax: 1.412.206.0146



© 2016 Brightline LP All Rights Reserved

*Specifications are subject to change without notice.*

