

# SeriesONE

# L1.4

## LED Studio Fixture Operating Instructions

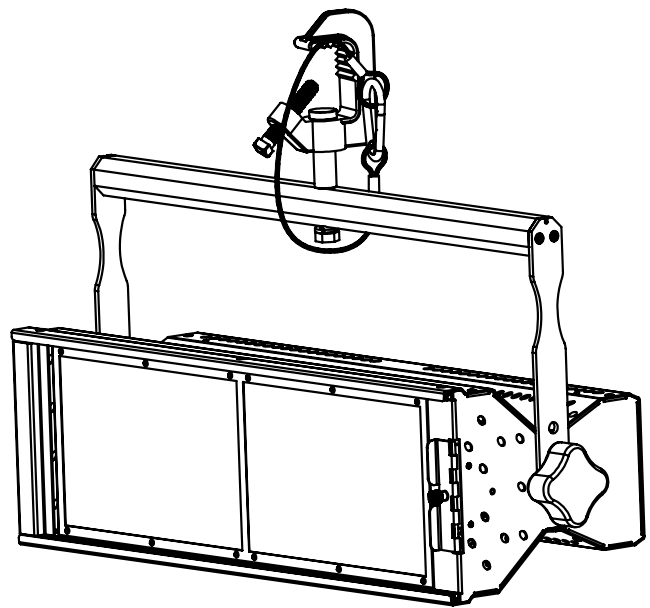
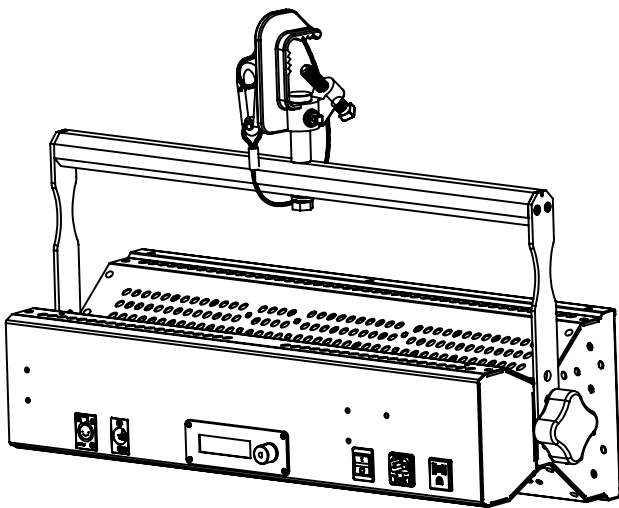

## Safety

- **WARNING:** To avoid possible damage to the driver, turn fixture “OFF” before connecting fixture to or disconnecting fixture from DMX control cable.
- Do not service fixture until the appropriate service manual has been read, and the unit has been completely de-energized.
- All fixtures are protected with a Slo-Blo Fuse 10-Amp, 250VAC 5x20mm.
- To prevent fire or shock hazard, do not expose the unit to water or moisture.
- Never carry fixture when energized.

## Owner’s Record

The model and serial number of this product can be found on the side of the fixture’s main housing. You should note the model number and the serial number in the space provided and retain this book for future reference as a permanent record of your purchase.

Model #: \_\_\_\_\_  
Serial #: \_\_\_\_\_  
Date of Purchase: \_\_\_\_\_

## Product Description

The Brightline L1.4 is a 200 watt, DMX512-controlled, energy-efficient LED light fixture. This fixture combines digital electronics with a state-of-the-art optical system to produce a soft, full-spectrum, flicker-free light source.

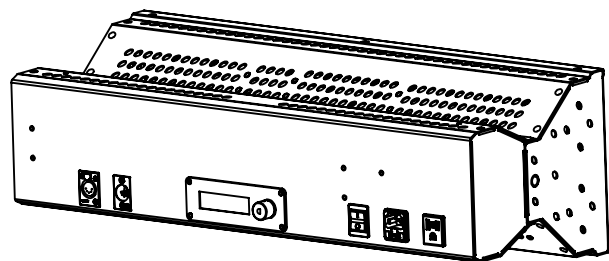
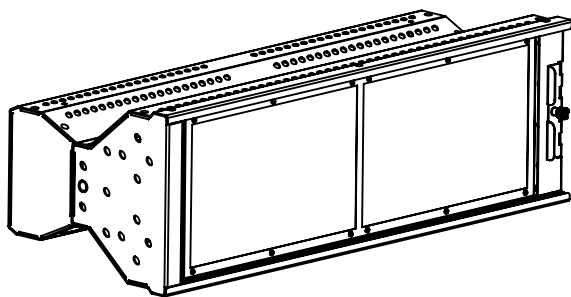

## DMX Cable Layout

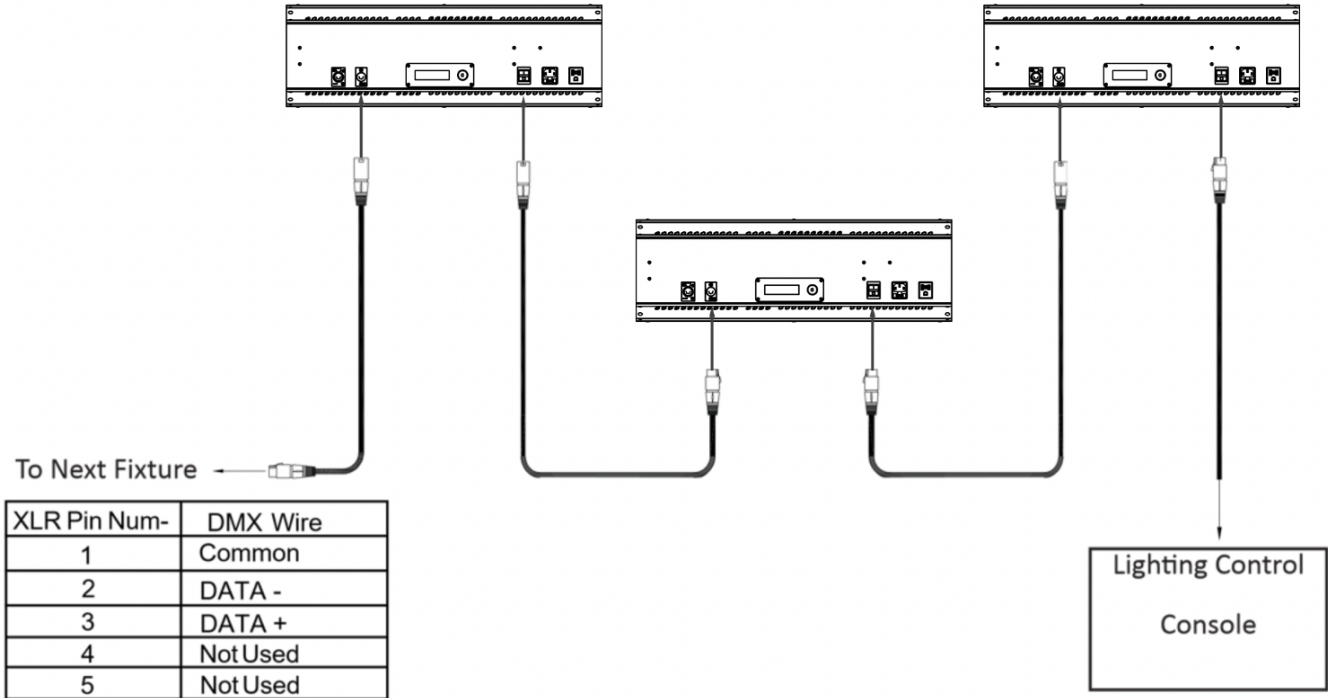

Table 1

### DMX Networking Guidelines

If you are connecting more than one DMX fixture, it is imperative to properly configure the DMX network. Following the guidelines below should reduce the possibility of networking errors.

1. Only cables intended for DMX operations should be used. Avoid DMX runs parallel to power cables, particularly those from dimmer racks.
2. Fixtures and other devices in a DMX network need to be configured in a daisy-chain fashion. The use of DMX “Y” devices or “twofer” is not advised.
3. You can use up to 32 Brightline DMX fixtures on a single DMX data line. If there are more than 32 units, the use of a DMX repeater amplifier or splitter amplifier is required. A repeater amplifier is an electronic device that boosts the DMX signal. A splitter amplifier is an electronic device that boosts the DMX signal and provides for multiple DMX outputs from a single DMX input since using multiple DMX devices may cause signal degradation.
4. Brightline DMX fixtures are self-terminating. No DMX termination switch is required. (With most DMX devices, there is a “DMX Thru/DMX Terminate: switch that is set to “Terminate” for the last device on the data line and set to “Through” for all other devices.)
5. Brightline fixtures, like the majority of DMX devices, use 5-pin, XLR-type plugs wired according to table 1. Pins 4 & 5 are not used, and so, on Brightline fixtures, are not connected to wiring. Pin 1 (shield) should be connected to earth ground only at the control console.

Note: These guidelines will help the user configure most DMX networks. For more information, contact the manufacturer of the control console, or a DMX manual. A useful DMX guide is “Recommended Practice for DMX-512” by Adam Benne e, co-published by PLASA in the United Kingdom and USITT in North America.

580 Mayer Street, Building #7, Bridgeville, PA 15017, USA

Brightlines.com | 1.412.206.0106



## Installing DMX Control Cables

1. Turn power “OFF” on all devices.

Note: If the fixture power is not turned “OFF” before connecting or disconnecting the DMX cable to the fixture, damage to the LED driver may result.

2. Insert the male plug end (Figure 3) into the appropriate female receptacle on the lighting control console.
3. Line up the locking key on the female plug end (Figure 4) with the male receptacle on the first fixture labeled “DMX IN.” Insert the plug into the receptacle until it locks into place.

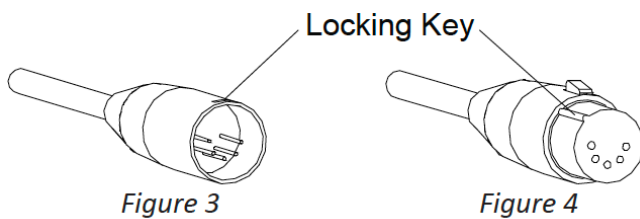

4. Program DMX addresses by gently pressing in the adjustment buttons with a pointed object such as a pen (Figure 10 on page 5) with the female receptacle labeled “DMX THRU” on the first fixture. Insert the plug into the receptacles until it locks into place.
5. Route the jumper cable to the next fixture.
6. Line up the locking key on the female plug end of the jumper cable (Figure 4) with the male receptacle labeled “DMX IN” on the next fixture. Insert the plug into the receptacle until it locks into place.
7. Repeat steps 4-6 for remaining fixtures.
8. Turn power “ON” on all devices.

## Disconnecting Cables

1. Turn power “OFF” on all devices.
2. To disconnect the female end of the cable, press down the release button on the plug and pull the plug out of receptacle. Pressure should be applied to the plug, not the cables.
3. To disconnect the male end of the cable, press in the release button on the female receptacle and pull the plug out of the receptacle. Pressure should be applied to the plug, not the cables.

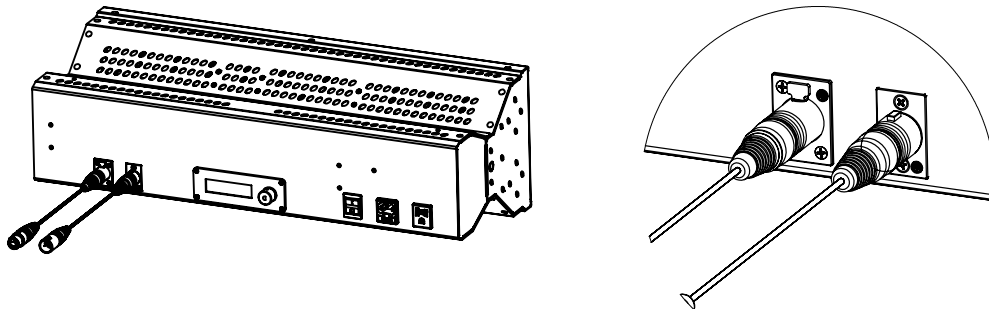

# Setting the DMX Address

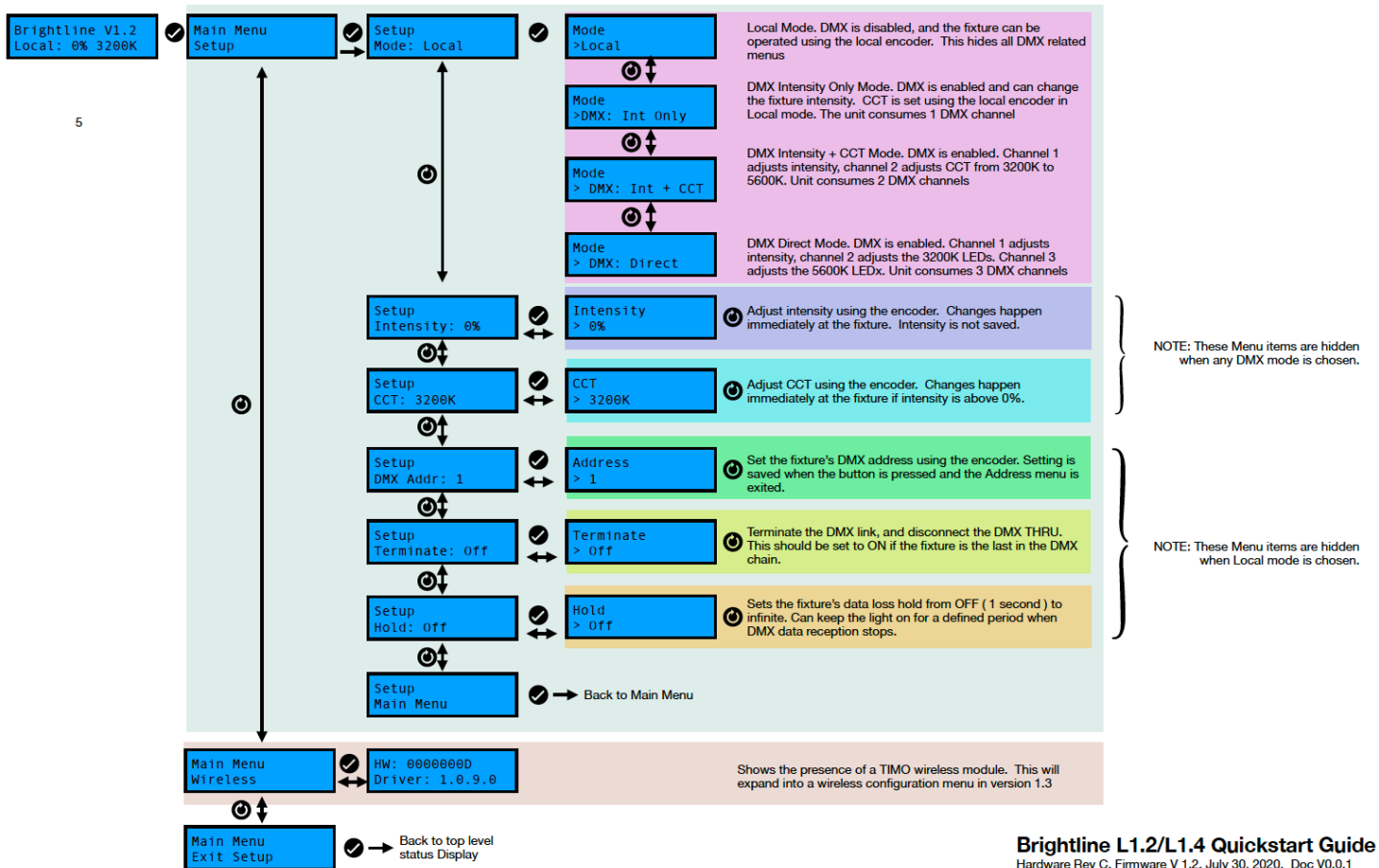
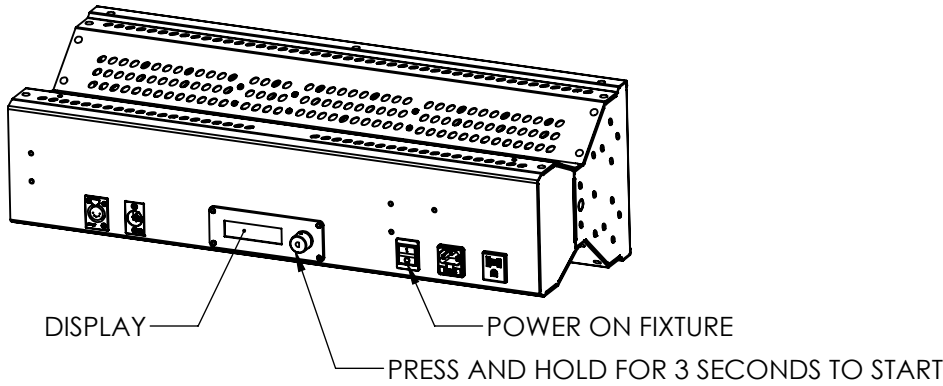

## Yoke Installation

