

Low-Voltage DMX Control

OPERATION GUIDE



580 Mayer Street, Building #7, Bridgeville, PA 15017, USA

Brightlines.com | 1.412.206.0106



Safety

- To prevent fire or shock hazard, do not expose the unit to water or moisture. Brightline fixtures are listed for indoor use only.
- Do not attempt to dim a non-dim fixture.
- A qualified technician should perform service on fixtures. Do not access internal components until the unit has been fully powered off.

Owner's Record

The model and serial number of this product can be found on the side of the fixture's main housing. You should note the model number and the serial number in the space provided and retain this book for future reference as a permanent record of your purchase.

Model #: _____

Serial #: _____

Date of Purchase: _____

Product Description

- Brightline's low-voltage control system facilitates an easy-to-set-up lighting system for video applications. Stand-alone systems are quoted with a DMX console and wall-mounted playback station (CTRL-WS-LV-SR516). Utilizing the DMX console, or another device with DMX output, set each module to the desired dimming level and record as an individual scene. When using the CTRL-WS-LV-SR516 you can record up to 16 individual scenes.
- The 6060 Power Driver ships configured for field operation.
- If there is more than one 6060 Power Driver within the system, the installer will need to set the DMX starting address on the additional 6060 Power Drivers (see page 3).
- All components necessary for operation of the 6060 Power Driver are included:
 - (1) 6060 Power Driver
 - (1) IEC power cord
 - (16 or 32) Phoenix connectors
 - (1) 1-foot RJ45 cable
 - (1) 1-foot DMX-5-Pin (M) to RJ45 adaptor

580 Mayer Street, Building #7, Bridgeville, PA 15017, USA

Brightlines.com | 1.412.206.0106



Operating Mode

Each 6060 Power Driver is configured to the required operating mode. If there is more than one 6060 Power Driver refer to DMX addressing information below.

A separate 6060 Power Driver is required for each fixture type in the installation. If the device is inadvertently reset to factory settings, call Tech Support at 1-412-206-0106 ex.113 or email techservice@brightlines.com for detailed instructions to re-configure the device for use with Brightline fixtures.

Setup

Locate your 6060 Power Driver in a control cabinet or 19-in rack (rack screws not included).

See the *Brightline Low-Voltage System Quick Setup Guide* for both DMX and power connection schemes.

See accompanying appendixes for fixture connection details.

Multiple 6060 Power Drivers can be linked with the DMX Thru (LED Sync Thru) jack and the included 1-ft RJ45 cable.

Configuring DMX Starting Address

All 6060 Power Drivers ship with factory configured settings so that the default DMX starting address is 1. See below for DMX address requirement for additional devices.

The DMX addresses will always move sequentially across ports 1-8.

To address unit:

Press [M]

DMX address will appear with the current starting address

Press [+ / -]

to adjust to desired starting address

Press [M]

to store DMX revised starting address (menu will exit after 5 second of inactivity)

	Flex-T Module	LST6	BL.16	LVCI	LVP2	LVP4
Qty per 6060PD	22	7	8	14	up to 8	up to 4
LV Wattage	27w	81w	34w	40.5w	27w	27w
Current Setting	800ma	800ma	700ma	800/400ma	800ma	800ma
Group Setting	3:3L	1:4L	1:4L	2:4L	3:3L	3:3L
DMX Addresses	24	8	8	16	8	8
Fixture Setup Instructions	Appx. A	Appx. B	Appx. C	Appx. D	Appx. E	Appx. F
Note: Each fixture type requires its own 6060 unit.						

Testing Fixtures after Installation

To test that fixtures are receiving power prior to connecting to a DMX controller:

1. Connect all fixtures and devices then power on your 6060 Power Driver.
2. Simultaneously press the [M, +, and -] buttons. DO NOT HOLD.
3. Each port position will turn on for one second sequentially, followed by all fixtures on for one second. This pattern will repeat twice. (Ex. R, G, B, W, then ALL, repeat).

Connecting a Wall Station

The CTRL-WS-LV-SR516 wall station comes with all necessary parts to integrate into the stand-alone low-voltage control system. To connect the CTRL-WS-LV-SR516 to the 6060 Power Driver, run the RJ45 to bare lead cable from the wall station to the DMX IN port on the back of the 6060 Power Driver, or to a DMX gateway networking device for integration with other controls. (see the **Brightline CTRL-WS-LV-SR516 Overview** for wiring instructions at the wall station). Ensure that the wall station is in line between the controller and the 6060 Power Driver for proper operation. See the **Brightline CTRL-WS-LV-SR516 Overview** for more detail.

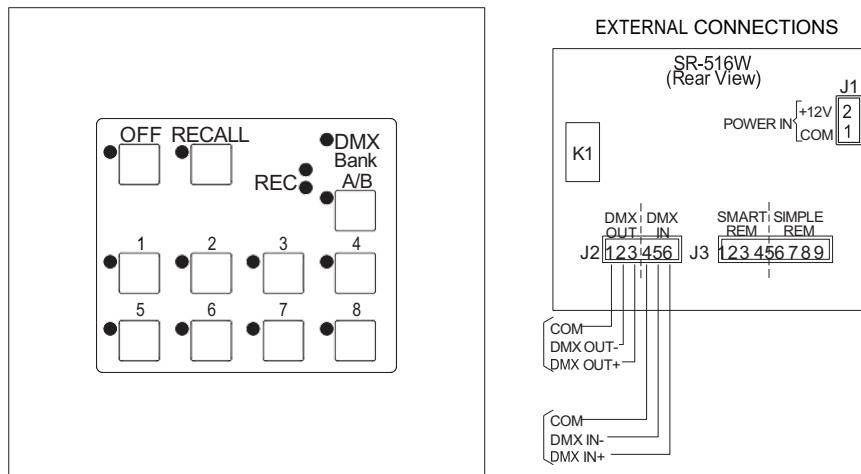

System Integration

A DMX IN signal is required for integration with non-Brightline provided control systems. A DMX 5-Pin (M) to RJ45 adaptor is provided by Brightline for convenience. Simply connect the control system to the DMX IN port. Consult manufacturers' documentation for setup and integration instructions.

Appendix A

Flex-T Fixtures

Operating Mode

Prior to shipment each 6060 Power Driver is configured to the required operating mode.

In the 3:3L operating mode, the first 3 positions for each port are active and usable. The 4th position on each port is disabled and inactive to prevent overload.

DMX addresses distribute sequentially by active position. Looking at the back of the device, addresses read from right to left, 1-24 (ex. with the 4th position inactive, position 5 is assigned DMX address 4).

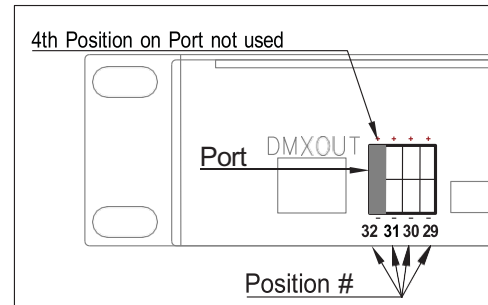

Connecting Fixtures

Up to (22) FLX-T modules can connect per 6060 Power Driver. Flex-T fixtures can be ordered with 1 or 2 modules.

Brightline's low-voltage fixtures cannot daisy chain. Each fixture must homerun back to the 6060 Power Driver.

Brightline's low-voltage Flex-T fixtures ship with a budgeted length of 75-ft of 16AWG single pair wiring per Flex-T module. Wire is provided as a coil, allowing for custom length measurements during installation.

(12) 3 position and (4) 2 position Phoenix connectors are provided for easy setup.

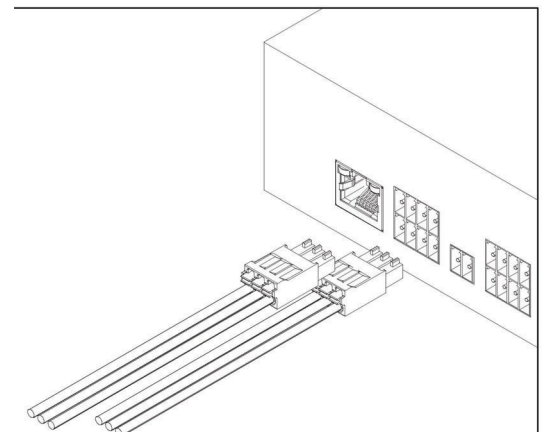

(Red +, Black -) OR (Black +, White -)

To connect FLX-T modules:

1. Measure, trim, and run wiring (1 wire run per Flex-T module).
2. To locate fast connect wire nuts, remove the fixture's cover plate with strain relief attached.
3. Feed wire through the strain relief and insert into the wire nut.
4. Homerun wiring back to the 6060 Power Driver and insert into the provided Phoenix connectors. Distribute load evenly over positions for best heat management. (2 positions will remain unused in a device with maximum fixture modules.)
5. Once wiring is seated in the Phoenix connectors, insert into the first 3 positions on each port.

Appendix B

LED Stealth-T Fixtures

Operating Mode

Prior to shipment each 6060 Power Driver is configured to the required operating mode.

In the 1:4L operating mode, all positions and ports are active and usable. All positions in a single port will be operable as a single DMX address.

DMX addresses distribute sequentially by port. Looking at the back of the device, addresses read from right to left, 1-8.

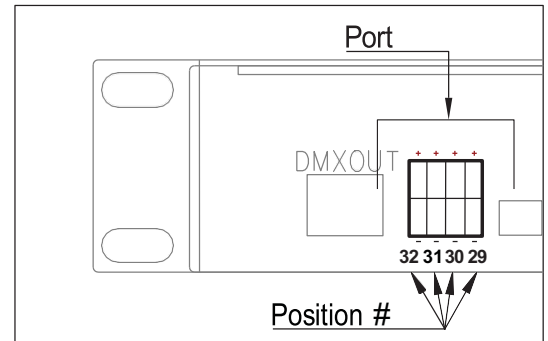

Connecting Fixtures

Up to (7) LST fixtures can connect per 6060 Power Driver.

Brightline's low-voltage fixtures cannot daisy chain. Each fixture must homerun back to the 6060 Power Driver.

Brightline's low-voltage LED Stealth-T fixtures require (3) wiring homeruns. Fixtures ship with a budgeted length of 225-ft of 16AWG single pair wiring. Wire is provided as a coil, allowing for custom length measurements during installation.

(16) 3-position Phoenix connectors are provided for easy setup.

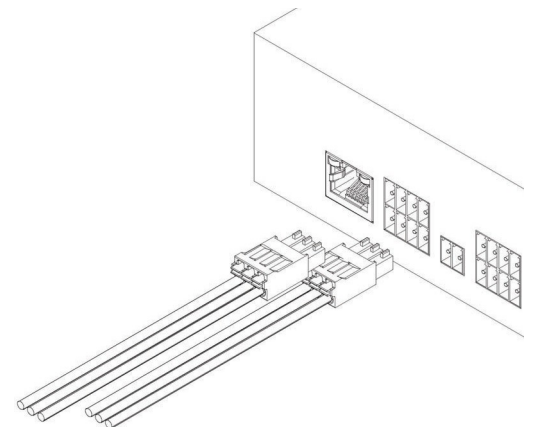

(Red +, Black -) OR (Black +, White -)

To connect LED Stealth-T fixtures:

1. Measure, trim, and run wiring per fixture (3 cable runs per LST fixture).
2. To locate fast connect wire nuts, remove the fixture's cover plate with strain relief attached.
3. Feed wire through the strain relief and insert into the wire nut.
4. Homerun the bundle back to the 6060 Power Driver and insert into the provided Phoenix connectors. Ensure that all 3 runs for a fixture are connected to a single port for accurate control.
5. Once wiring is seated in the Phoenix connectors, insert into the first 3 positions on each port.

Appendix C

BL.16 Fixtures

Operating Mode

Prior to shipment each 6060 Power Driver is configured to the ideal operating mode.

In the 1:4L operating mode, all positions and ports are active and usable.

DMX addresses distribute sequentially by port. Looking at the back of the unit address, read from right to left, 1-8.

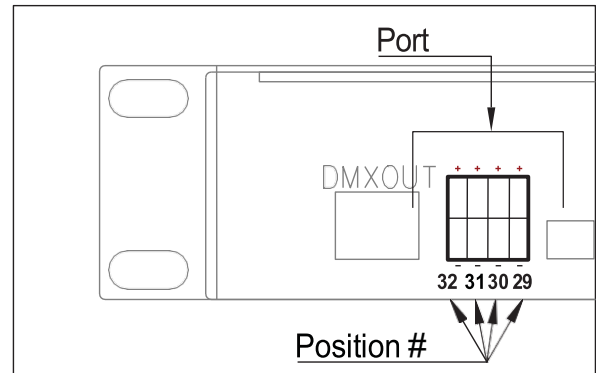

Connecting Fixtures

Up to 8 BL.16 fixtures can be connected per 6060 Power Driver.

Brightline's low-voltage fixtures cannot daisy chain. Each fixture must homerun back to the 6060 Power Driver.

Brightline's low-voltage BL.16 fixtures require a single homerun. Fixtures ship with a budgeted length of 75-ft of 8-conductor wiring. Wire is provided as a coil, allowing for custom length measurements during installation.

(16) 4-position Phoenix connectors are provided for easy setup.

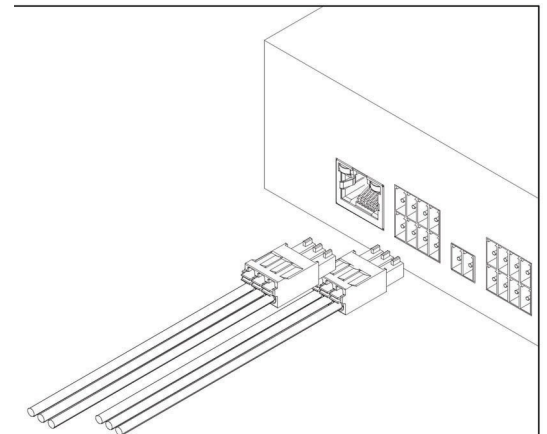

(Red +, Black -) OR (Black +, White -)

To connect BL.16 fixtures:

1. Measure and run wiring per fixture.
2. At the fixture connect the circular connector.
3. Homerun the bundle back to the 6060 Power Driver and insert into the provided Phoenix connectors. Ensure that all 4 pairs for a fixture are connected to a single port for accurate control.
4. Once wiring is seated in the Phoenix connectors, insert into each port.

Appendix D

LVCI Fixtures

Operating Mode

Prior to shipment each 6060 Power Driver is configured to the required operating mode.

In the 2:4L operating mode, all positions in a port are active and are grouped in sequential pairs (Ex. The first two positions are both controlled by DMX address 1).

DMX addresses will automatically distribute sequentially. Looking at the back of the device, addresses distribute from right to left, 1-14.

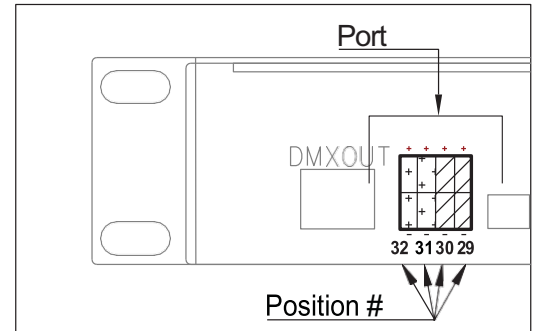

Connecting Fixtures

Up to (14) LVCI fixtures can connect per 6060 Power Driver.

Brightline's low-voltage fixtures cannot daisy chain. Each fixture must homerun back to the 6060 Power Driver.

Brightline's low-voltage LVCI fixtures require (2) wiring homeruns. Fixtures ship with a budgeted length of 150-ft of 16AWG single pair wiring. Wire is provided as a coil, allowing for custom length measurements during installation.

(32) 2-position Phoenix connectors are provided for easy setup.

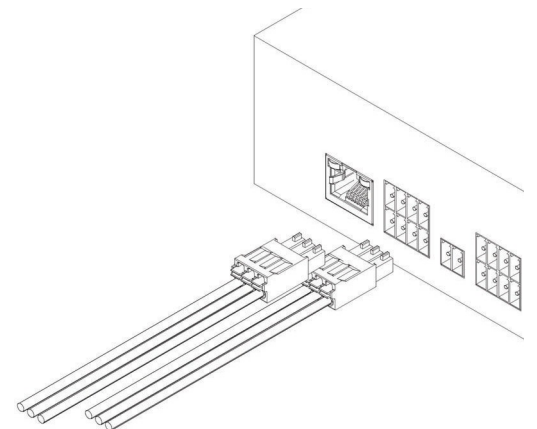

(Red +, Black -) OR (Black +, White -)

To connect LVCI fixtures:

1. Measure and run wiring per fixture (2 cable runs per LVCI fixture).
2. To locate fast connect wire nuts, remove the fixture's cover plate with strain relief attached.
3. Feed wire through the strain relief and insert into the wire nut.
4. Homerun the wiring back to the 6060 Power Driver and insert into the provided Phoenix connectors. Ensure that both runs for a fixture are connected to a single port for accurate control.
5. Once wiring is seated in the Phoenix connectors, insert into 2 positions on each port.

Appendix E

LVP 2-Foot Fixtures

Operating Mode

Prior to shipment each 6060 Power Driver is configured to the required operating mode.

In the 3:3L operating mode, all positions and ports are active and usable. All positions in a single port will be operable as a single DMX address.

DMX addresses distribute sequentially by port. Looking at the back of the device, addresses read from right to left, 1-21.

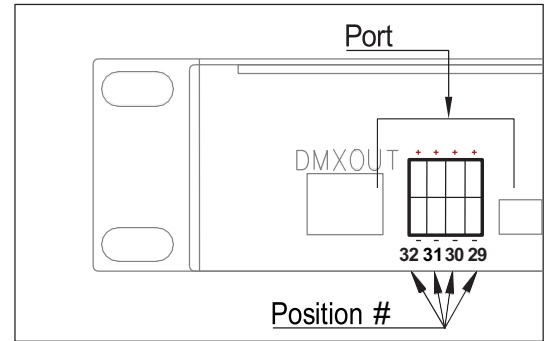

Connecting Fixtures

Up to (7) 2-foot LVP sections can connect per 6060 Power Driver. Each 2-foot channel section requires a single port for operation.

Brightline’s low-voltage fixtures cannot daisy chain. Each fixture must homerun back to the 6060 Power Driver.

Brightline’s low-voltage LED VideoPlus 2-foot channel section requires a wiring homerun. Fixtures ship with a budgeted length of 75-ft of 16AWG single pair wiring per 2-foot channel section. Wire is provided as a coil, allowing for custom length measurements during installation. (ex. a 2-foot LVP with Video-Task-Video [3 channels] will require 3 homeruns.)

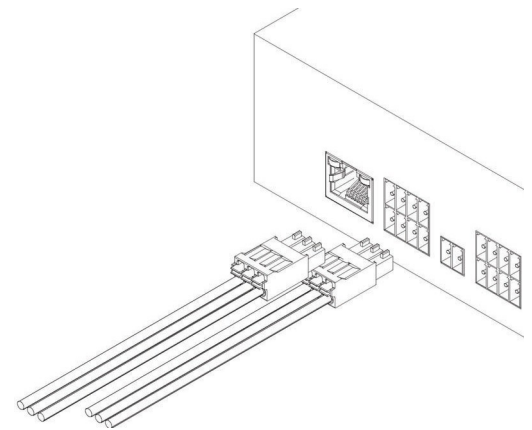

(Red +, Black -) OR (Black +, White -)

(7) 3-position Phoenix connectors are provided for easy setup.

To connect LED VideoPlus fixtures:

1. Measure, trim, and run wiring per fixture channel.
2. To locate fast connect wire nuts, remove the fixture’s cover plate with strain relief attached.
3. Feed wire through the strain relief and insert into the wire nut.
4. Homerun the wiring to the 6060 Power Driver and insert into the provided Phoenix connectors.
5. Once wiring is seated in the Phoenix connectors, insert into each port.

Appendix F

LVP 4-Foot Fixtures

Operating Mode

Prior to shipment each 6060 Power Driver is configured to the required operating mode.

In the 3:3L operating mode, all positions and ports are active and usable. All positions in a single port will be operable as a single DMX address.

DMX addresses distribute sequentially by port. Looking at the back of the device, addresses read from right to left, 1-18.

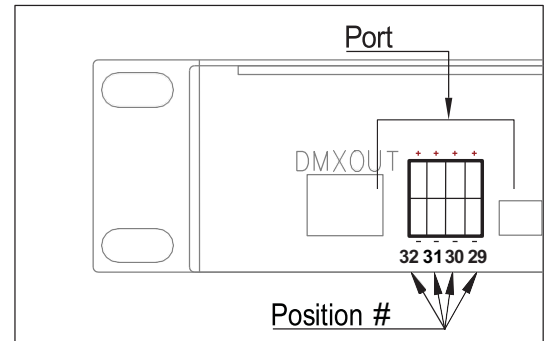

Connecting Fixtures

Up to (2) 4-foot LVP sections (8 linear feet) can connect per 6060 Power Driver. Each 4-foot LVP requires 2 ports per channel section for operation.

Brightline's low-voltage fixtures cannot daisy chain. Each fixture must homerun back to the 6060 Power Driver.

Brightline's low-voltage LED VideoPlus 4-foot channel section requires 2 wiring homeruns. Fixtures ship with a budgeted length of 150-ft of 16AWG single pair wiring per 4-foot channel section. Wire is provided as a coil, allowing for custom length measurements during installation. (ex. a 4-foot LVP with Video-Task-Video [3 channels] will require 6 homeruns.)

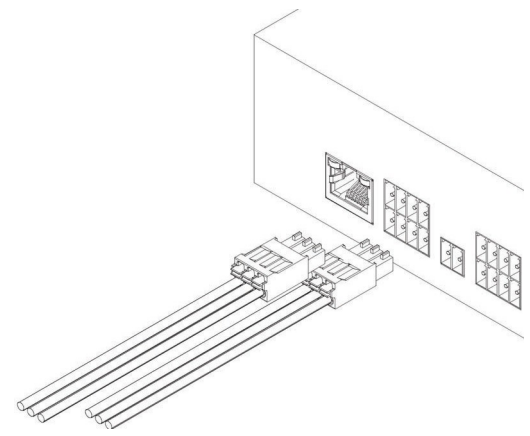

(Red +, Black -) OR (Black +, White -)

(8) 3-position Phoenix connectors are provided for easy setup.

To connect LED VideoPlus fixtures:

1. Measure, trim, and run wiring per fixture channel.
2. To locate fast connect wire nuts, remove the fixture's cover plate with strain relief attached.
3. Feed wire through the strain relief and insert into the wire nut.
4. Homerun the wiring to the 6060 Power Driver and insert into the provided Phoenix connectors.
5. Once wiring is seated in the Phoenix connectors, insert into each port.

WARRANTY

Brightline guarantees all its products to be free from defects in materials and workmanship for a period of three (3) years from the date of shipment.

PROCEDURES

If any product is found to be unsatisfactory under this warranty, the buyer must notify **Brightline** immediately. Once a course of action has been determined, if it is necessary to return the product to **Brightline** a Return Authorization (RA) will be issued. Ship the product directly to **Brightline**, 580 Mayer Street, Building #7, Bridgeville, PA 15017, USA. The RA number should be marked on the shipping carton. The unit will be replaced or put into proper operating condition, free of all charges if under warranty. The correction of any defects through repair or replacement by **Brightline** shall constitute fulfillment of all obligations and liability of **Brightline** to the buyer under this warranty and the contract of sale.

DISCLAIMERS

Brightline is not responsible for damage to its products caused by improper installation, maintenance, or use; by improper electrical hookups; or by unauthorized repairs.

Failure to notify **Brightline** of unsatisfactory operation or any improper or unauthorized installation, maintenance, use, repairs, or adjustments shall terminate the warranty and **Brightline** shall have no further responsibility under the warranty. **Brightline** shall not be liable for special or consequential damages in any claim, action, suit, or proceeding arising under this warranty or contract of sale, nor shall **Brightline** be liable for claims for labor, loss of profits or goodwill, repairs, or other expenses incidental to replacement. **Brightline** makes no other warranty of any kind whatsoever, expressed or implied, and all implied warranties of merchantability and fitness for a particular purpose that exceed the obligation specifically described in this warranty are hereby disclaimed by **Brightline** and excluded from this agreement.

All shipments, unless otherwise noted, are F.O.B. factory.

The customer is advised to inspect for shipping damage, apparent and/or hidden. If detected, notify the transportation company and file your claim.