



LED Flex-T

Operating Instructions

Overview

Safety

- Fixture installation should be performed in accordance with local and national codes. All fixtures must be properly grounded.
- To prevent fire or electric shock, do not expose the fixtures to water or moisture. Flex-T fixtures are listed for indoor use only.
- A qualified technician should perform service on fixtures. Do not remove the driver cover until the unit has been de-energized.

Owner's Record

The serial number of this product can be found on the top of the fixture. You should note the model number and the serial number in the space provided and retain this book for future reference as a permanent record of your purchase.

Model #: _____

Serial #: _____

Date of Purchase: _____

Product Description

The Brightline Flex-T models are single and double channel, LED videoconferencing fixtures that mount in a 2-ft x 2-ft or 600mm x 600mm T-bar ceiling or gypsum/drywall ceiling. These fixtures combine high-frequency electronics with a state-of-the-art optical system to produce a soft, full-spectrum, flicker-free light source.

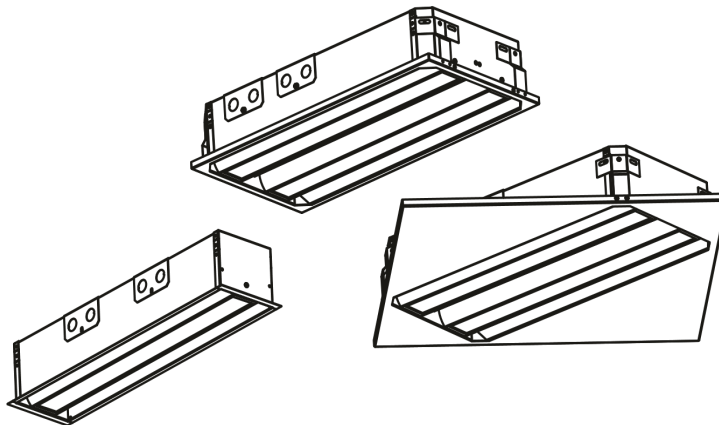

580 Mayer Street, Building #7, Bridgeville, PA 15017, USA

Brightlines.com | 1.412.206.0106



Specifications

Housing

20-gauge (.036") formed, cold-rolled steel sheet metal construction

Heat sink

6063-T5 Aluminum Extrusion

LED Drivers (integral drivers)

Control - 0-10V or DALI

Input: 120-277V, 50/60Hz, 1.05A max

Output: 48v, 1.05A, 50-100W

Please contact factory for exact driver specification and custom configurations

LED Drivers (remote drivers)

Control - DMX

Color Temperature

3000K: 50,000 hours - 97CRI

3500K: 50,000 hours - 97CRI

4000K: 50,000 hours - 97CRI

5000K: 50,000 hours - 97CRI

Finish

Low-glare, polyester powder coat, RAL 9003 Signal White

1. Unpack the fixtures. Accessories may be packed with the fixtures or separately. To prevent damage, do not attempt to install the fixtures with accessories in place.
2. Prepare the line voltage wiring to the fixtures. You may want to partially install the power wiring before the fixture is placed in the T-bar or drywall ceiling, if access is difficult. Ensure that the supply voltage matches that required by the driver. To install the power feed, loosen the screw holding the power entry plate and remove the plate (Figure 1). Remove the knockouts as needed and install the correct type of power cabling and strain relief (not provided). Connect the wires from the feed using wire-nuts, observing the wire color coding, and re-install the knockout plate. Brightline fixtures intended for the North American market use black/white/green wires respectively for line/neutral/ground; fixtures shipped to other locations use brown/blue/green-yellow for line/ neutral/ground. In most cases, it is useful to install sufficient slack in the power cable so that the fixture may be moved to an adjacent tile opening without having to extend the wiring.

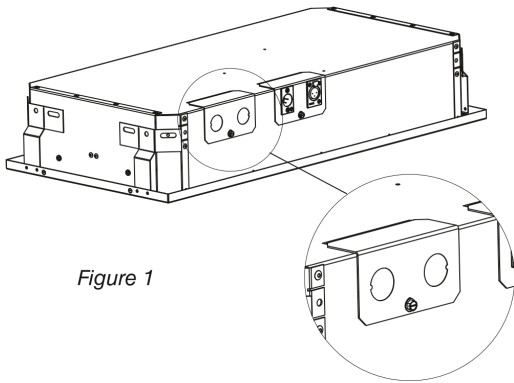

Figure 1

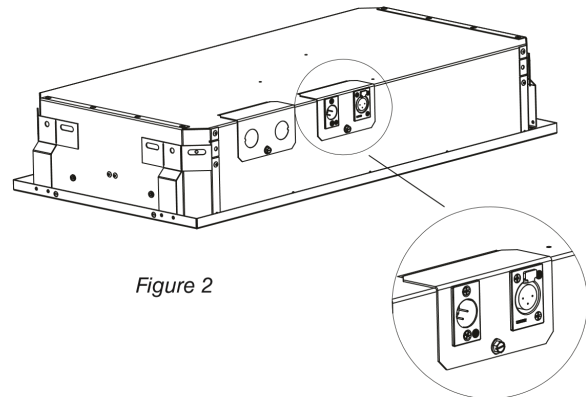

Figure 2

3. If the fixture requires digital control, the fixture will have locking XLR-type plugs for the control cables. Install the control wiring above the T-bar grid. Male and female plugs are installed into receptacles (Figure 2) on each fixture; as they are wired in parallel, the control wiring can be daisy-chained. See the Control Wiring section.

4. Prepare the T-bar to receive the fixtures. Flex-T fixtures are either a nominal 6-in x 2-ft (155mm x 1220mm), 1-ft x 2-ft (305mm x 610mm) or 2-ft x 2-ft (610mm x 610mm) size. It may be necessary to add additional track sections and/or prepare differently sized ceiling tiles. For ease of installation, a minimum of 8-in (200mm) of clear height above the track is recommended. Make sure that the T-bar is sufficiently braced to accept the weight of the fixtures; these fixtures weigh: 6-in x2-ft – 9.5 pounds; 1-ft x 2-ft – 21.45 pounds; 2-ft x 2-ft – 24.51 pounds.
5. Place the fixtures into the correct openings in the ceiling grid in accordance with plans provided by Brightline or the local architect or engineer. Brightline fixtures are not Insulated Ceiling (IC) rated. Maintain the proper distance from insulation.
6. Install safety wires on the tabs on the top of the fixtures and attach to the building structure, in compliance with local codes (Figure 3). Do not rely on the T-bar alone to hold the weight of the fixture.

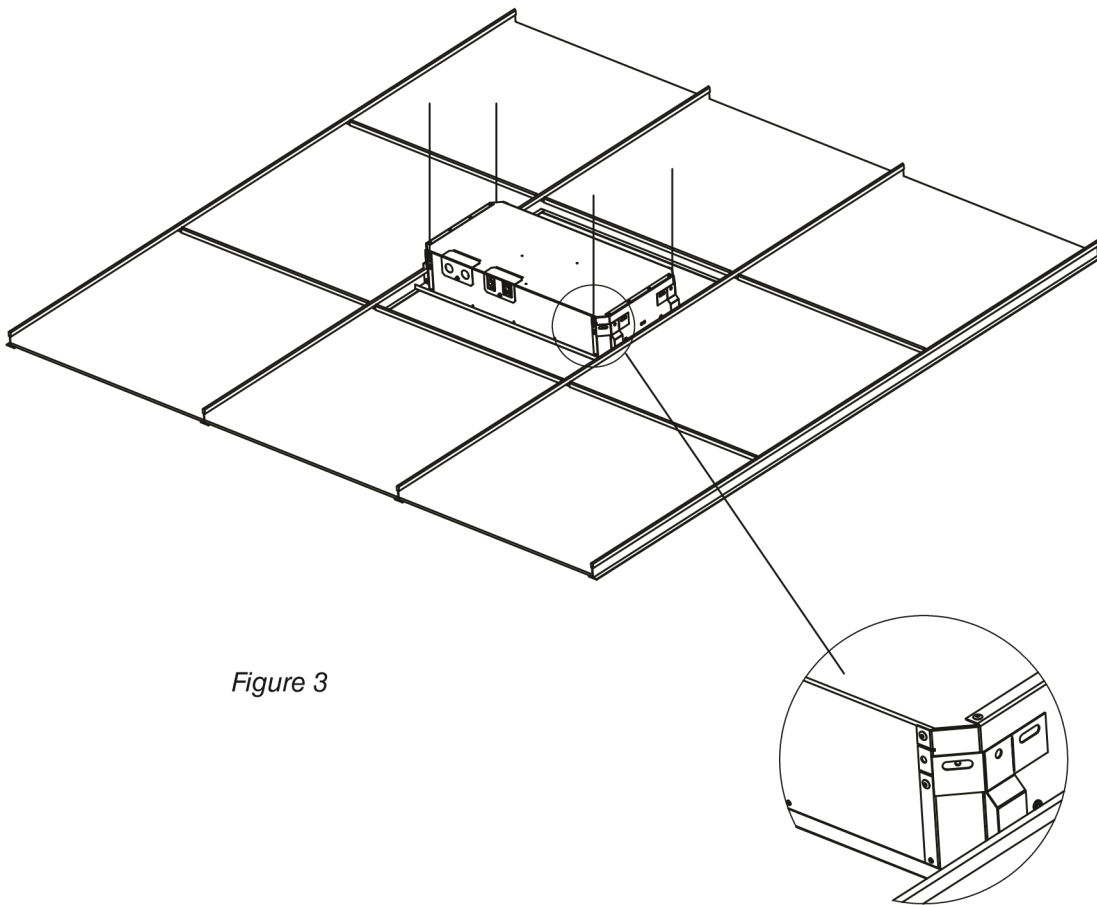
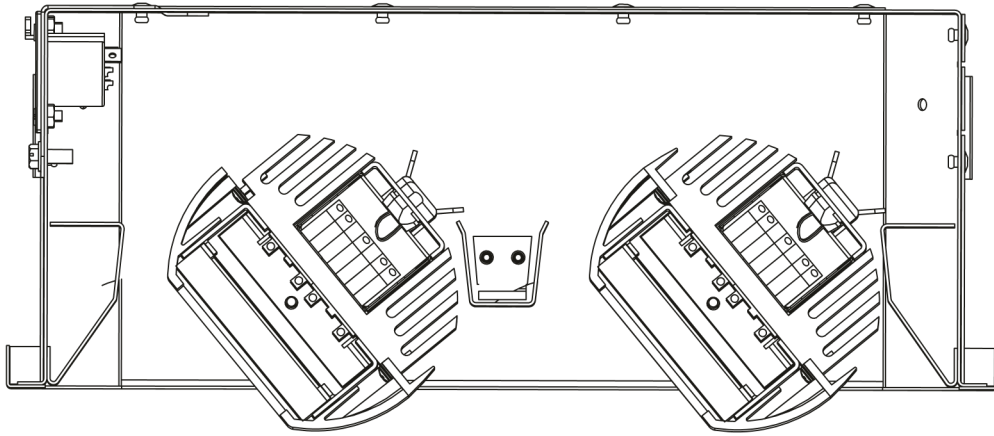

Figure 3

7. Complete the installation of the power (and control, if required) wiring. See the Riser Diagram section.
8. Aim the fixture video channel in compliance with the directions provided by Brightline or the specifier. The video channel can swivel between 0° to 50° from horizontal.



Trouble Shooting Guide

Problem	Possible Cause	Solution
Light flickers or drops out at low end.	Driver not configured properly.	Consult factory.
Lights are flashing or flickering.	Loose wiring connection or insulation may be covering fixture.	Make sure wiring is secure. Remove any insulation surrounding fixture. Consult factory.

Maintenance

The LEDs are rated for up to 50,000 hours. However, as with all LEDs there will be some drop-off in intensity as they approach their rated life. We recommend that as the LED intensity begins to drop off, or when the life expectancy is reached, all room fixtures are replaced, as a group.

DALI Riser

AV Processor Option

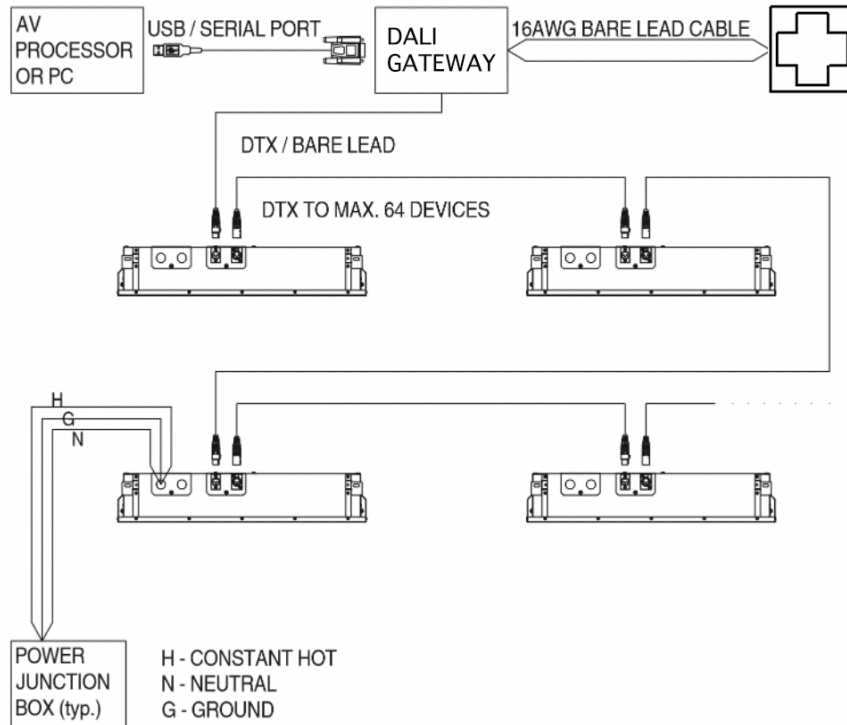

Notes:

A DALI (Digital Addressable Lighting Interface) signal controls these fixtures. The fixtures will function (as switched on/off) in the absence of a control signal.

The control signal is connected to the fixture through the 3-pin XLR-type receptacle on the side of the unit. As this is low voltage wiring, it may not be necessary to install the control wiring in conduit. Brightline recommends that it provides the DALI control cables as part of your system order. Specification should be verified with Brightline if control cables are provided by others. Two receptacles are provided to allow the control wiring to be daisy-chained.

As each fixture is assigned an individual address, fixtures on a DALI control line may be dimmed to differing intensities.

DALI control wiring is topology and polarity independent. DALI control cables may be daisy-chained. Keep total wire run as short as possible. See the literature that is provided with your DALI controller, or contact Brightline for details.

Power for the DALI network is provided by the DALI PS. The Gateway and the DALI network are configured by using the supplied DALI Cockpit software. Optionally, the Gateway may be controlled by an A/V processor via its RS-232 serial interface.

580 Mayer Street, Building #7, Bridgeville, PA 15017, USA

Brightlines.com | 1.412.206.0106



Each fixture requires a source of unswitched AC power. For clarity, only one fixture's power feed is shown.

DALI Riser

Stand-Alone Option

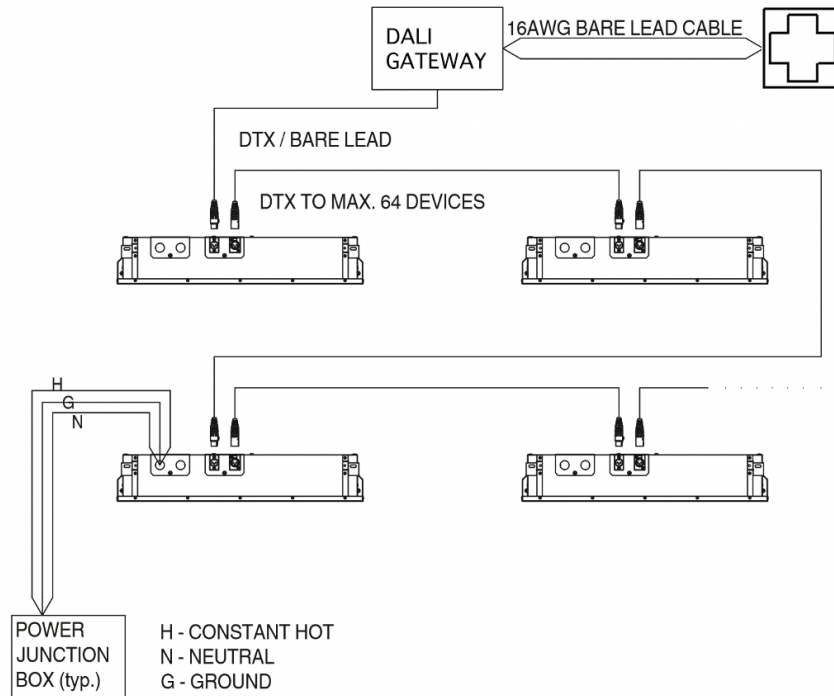

Notes:

A DALI (Digital Addressable Lighting Interface) signal controls these fixtures. The fixtures will function (as switched on/off) in the absence of a control signal.

The control signal is connected to the fixture through the 3-pin XLR-type receptacle on the side of the unit. As this is low voltage wiring, it may not be necessary to install the control wiring in conduit. Brightline recommends that it provides the DALI control cables as part of your system order. Specification should be verified with Brightline if control cables are provided by others. Two receptacles are provided to allow the control wiring to be daisy-chained.

As each fixture is assigned an individual address, fixtures on a DALI control line may be dimmed to differing intensities.

DALI control wiring is topology and polarity independent. DALI control cables may be daisy-chained. Keep total wire run as short as possible. Reference the literature that is provided with your DALI controller, or contact Brightline for details.

580 Mayer Street, Building #7, Bridgeville, PA 15017, USA

Brightlines.com | 1.412.206.0106



Power for the DALI network is provided by a separate power supply. Installation instructions are included with DALI Gateway.

Each fixture requires a source of unswitched AC power. For clarity, only one fixture's power feed is shown.

0-10V Riser

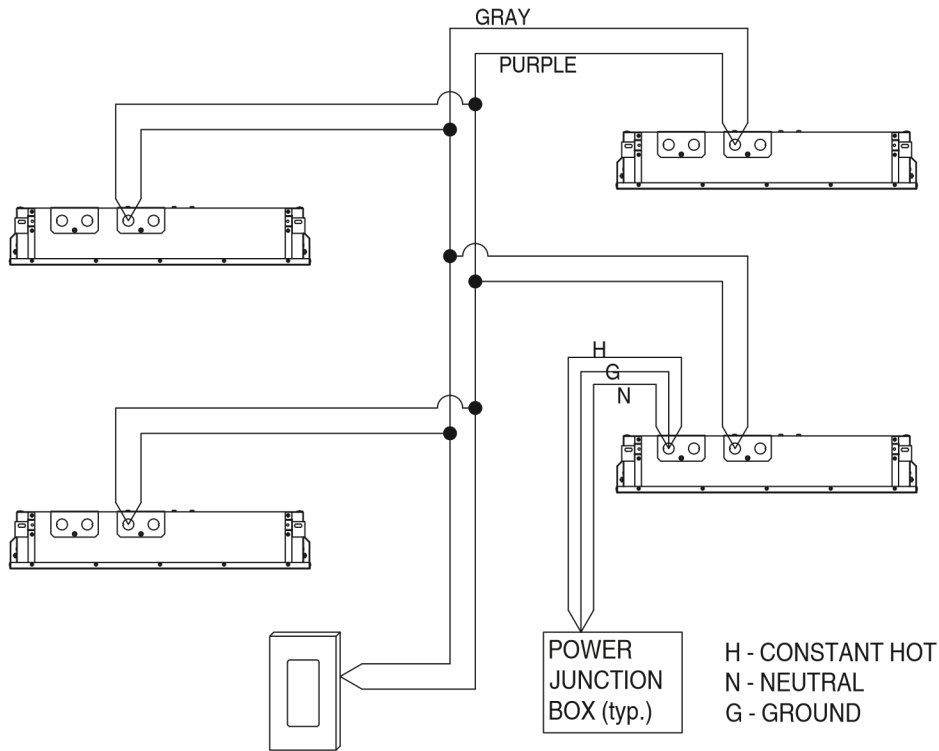

Notes:

Fixture provided with one 0-10V driver

0-10V Dimming - 150 μ A source current from driver

Low Voltage DMX Riser

Single Module Fixtures

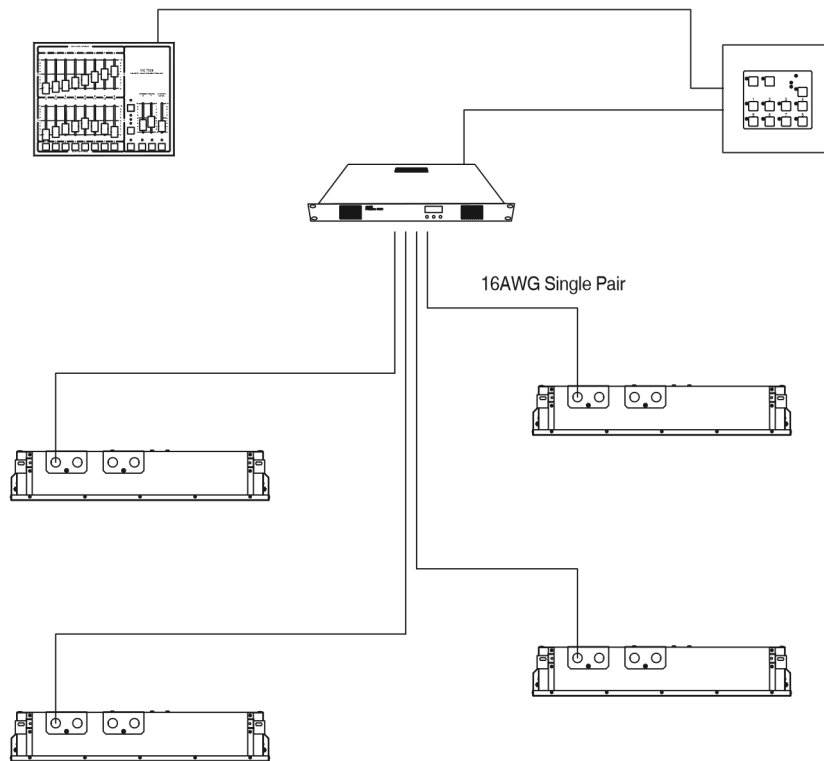

* Each Flex-T modules requires individual homerun

Notes:

DMX addresses distribute sequentially by active position. Looking at the back of the device, addresses read from right to left, 1-24 (ex. with the 4th position inactive, position 5 is assigned DMX address 4).

Up to (22) FLX-T modules can connect per 6060 Power Driver.

Brightline's low-voltage fixtures cannot daisy chain. Each fixture must homerun back to the 6060 Power Driver.

Brightline's low-voltage Flex-T fixtures ship with a budgeted length of 75-ft of 16AWG single pair wiring per Flex-T module. Wire is provided as a coil, allowing for custom length measurements during installation.

580 Mayer Street, Building #7, Bridgeville, PA 15017, USA

Brightlines.com | 1.412.206.0106



Low Voltage DMX Riser

Two Module Fixtures

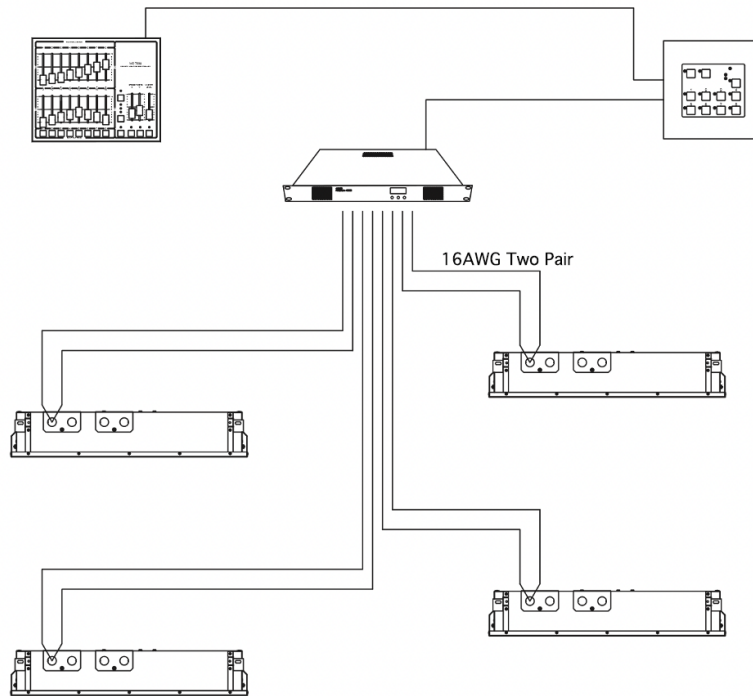

* Each Flex-T modules requires individual homerun

Notes:

DMX addresses distribute sequentially by active position. Looking at the back of the device, addresses read from right to left, 1-24 (ex. with the 4th position inactive, position 5 is assigned DMX address 4).

Up to (22) FLX-T modules can connect per 6060 Power Driver.

Brightline's low-voltage fixtures cannot daisy chain. Each fixture must homerun back to the 6060 Power Driver.

Brightline's low-voltage Flex-T fixtures ship with a budgeted length of 75-ft of 16AWG single pair wiring per Flex-T module. Wire is provided as a coil, allowing for custom length measurements during installation.

580 Mayer Street, Building #7, Bridgeville, PA 15017, USA

Brightlines.com | 1.412.206.0106



WARRANTY

Brightline guarantees all its products to be free from defects in materials and workmanship for a period of one (1) year from the date of shipment.

PROCEDURES

If any product is found to be unsatisfactory under this warranty, the buyer must notify **Brightline** immediately. Once a course of action has been determined, if it is necessary to return the product to **Brightline**, a Return Authorization (RA) will be issued. Ship the product directly to **Brightline**, 580 Mayer Street, Building #7, Bridgeville, PA 15017 USA. The RA number should be marked on the shipping carton. The unit will be replaced or put into proper operating condition, free of all charges. The correction of any defects through repair or replacement by **Brightline** shall constitute fulfillment of all obligations and liability of **Brightline** to the buyer under this warranty and the contract of sale.

DISCLAIMERS

Brightline is not responsible for damage to its products caused by improper installation, maintenance, or use, by improper electrical hookups, or by unauthorized repairs.

Failure to notify **Brightline** of unsatisfactory operation or any improper or unauthorized installation, maintenance, use, repairs, or adjustments shall terminate the warranty and **Brightline** shall have no further responsibility under the warranty.

Brightline shall not be liable for special or consequential damages in any claim, action, suit, or proceeding arising under this warranty or contract of sale, nor shall **Brightline** be liable for claims for labor, loss of profits or goodwill, repairs, or other expenses incidental to replacement. **Brightline** makes no other warranty of any kind whatsoever, expressed, or implied, and all implied warranties of merchantability and fitness for a particular purpose that exceed the obligation specifically described in this warranty are hereby disclaimed by **Brightline** and excluded from this agreement.

All shipments, unless otherwise noted, are F.O.B. factory.

The customer is advised to inspect for shipping damage, apparent and/or hidden. If detected, notify the transportation company and file your claim.

580 Mayer Street, Building #7, Bridgeville, PA 15017, USA

Brightlines.com | 1.412.206.0106

