



AV/720

Operating Instructions

Overview

Safety

- AV/720 installation should be performed in accordance with local and national codes. The AV/720 fixtures must be properly grounded.
- To prevent fire or electric shock, do not expose the AV/720 to water or moisture. The AV/720 is listed for indoor use only.
- A qualified technician should perform service on the AV/720. Do not remove the cover.

Owner's Record

The serial number of this product can be found on the top cover. You should note the model number and the serial number in the space provided and retain this book for future reference as a permanent record of your purchase.

Model #:

Serial #:

Date of Purchase:

Product Description

The AV/720 comes preprogrammed from the factory. Brightline's AV/720 low-voltage control system facilitates an easy-to-setup lighting system for video applications. Using Class 2 wiring, the AV/720 Driver can control up to 600W.



580 Mayer Street, Building #9, Bridgeville, PA 15017, USA

Brightlines.com | 1-412-206-0106



Specifications

LED Control Driver (P/N CTRL-RPD-LV-AV/720)

Input Characteristics

- Input voltage: AC 120v – 230v
- Input current: 6.3A max at 120V/60Hz.

Output Characteristics

- Output power: 600W max.
- Adjustable output voltage: 2-48V

Control Characteristics

- Control Channels: up to 40 DMX channels.
- Pre-configured by factory
- Dimming Curve – Logarithmic (default) / Linear

Certifications

- ETL – US and Canada
- CE

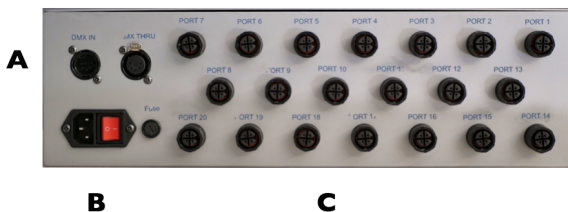

Width: 19" (482.6mm)
Height: 5.37" (136.4mm)
Depth: 13.2" (335.3mm)
Weight: 16.75 lbs. (7.60kg)



A: DMX In / Thru
B: Power In – ON / OFF Switch
C: 4-PIN Connector
D: Display and Dial

Installation Options

- ▶ Rack Mount – 3U
- ▶ Powered by standard AC plug
- ▶ Ceiling Mount
 - ▶ Electrical Contractor Required (Refer to diagram below)



Mounting hardware not by Brightline

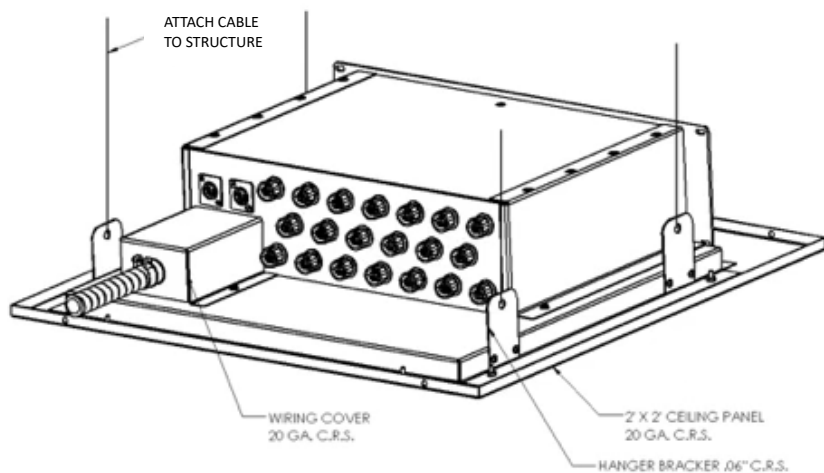

Note: with ceiling tray, AV/720 weight is 32 LBS.

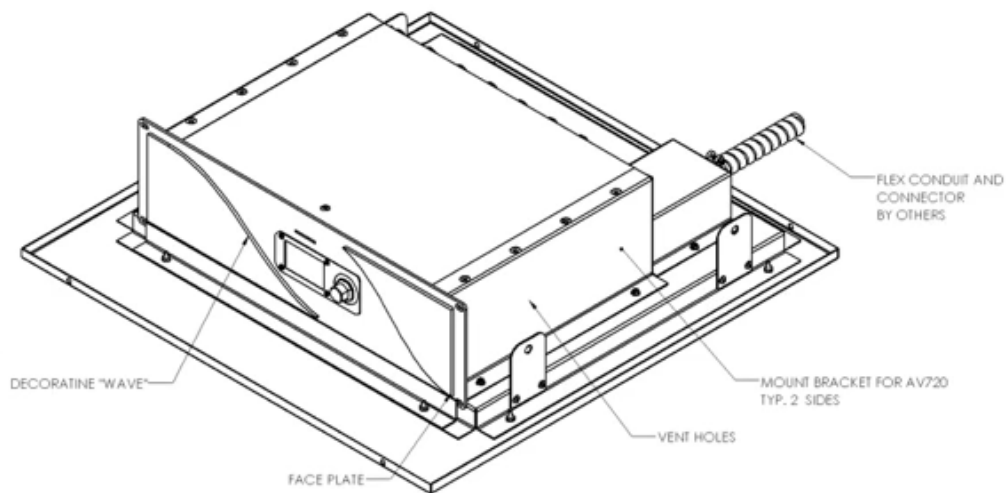

AV/720

- ▶ 600W Power Supply
- ▶ 20 Outputs
- ▶ Up to 40 DMX Channels
- ▶ Arrives Pre-Programmed

Any combination of Brightline fixtures in the low voltage family up to 600 watts, can be used with an AV/720.

Please refer to the project layout that was provided with the AV/720.

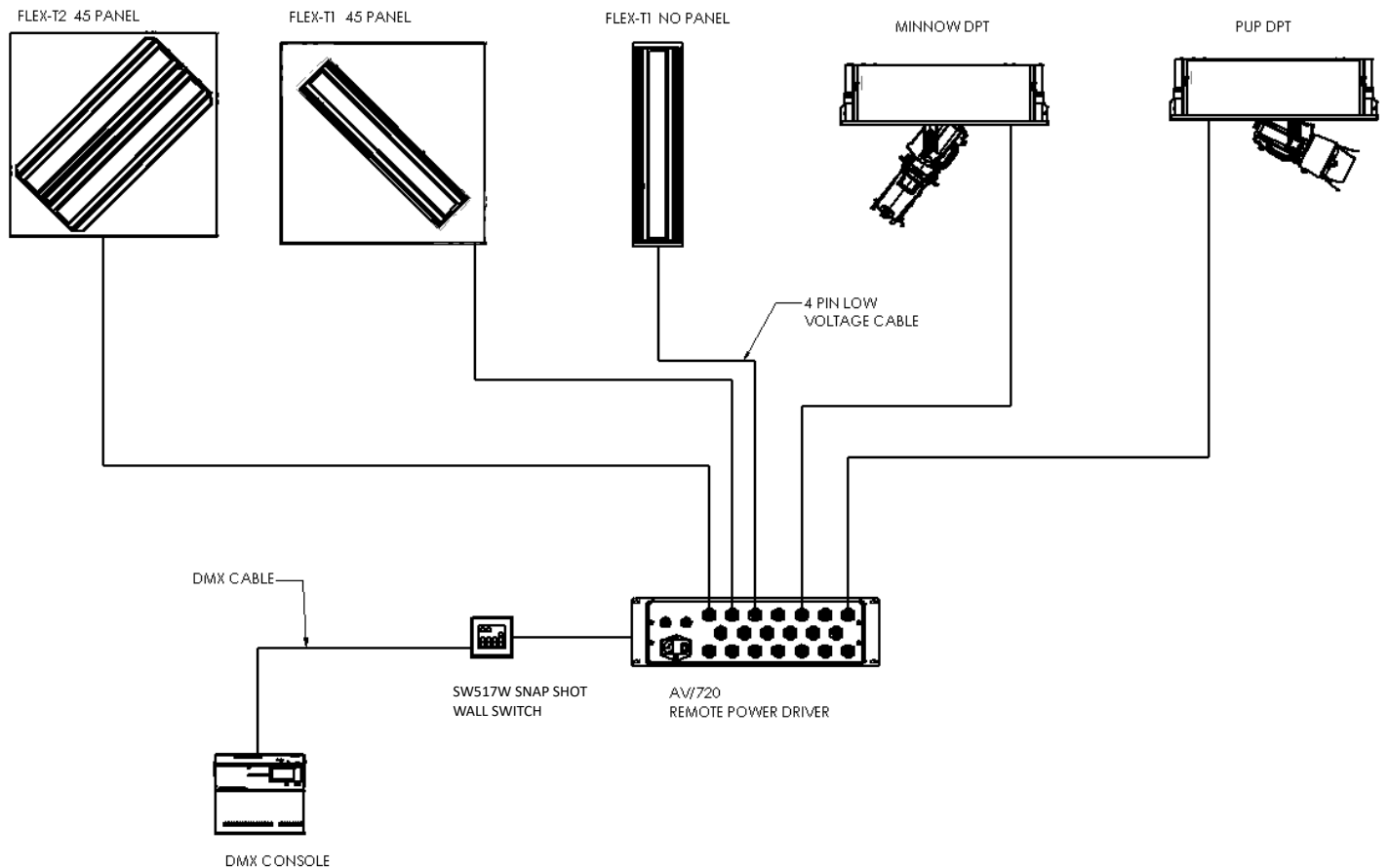

Project Layout Example

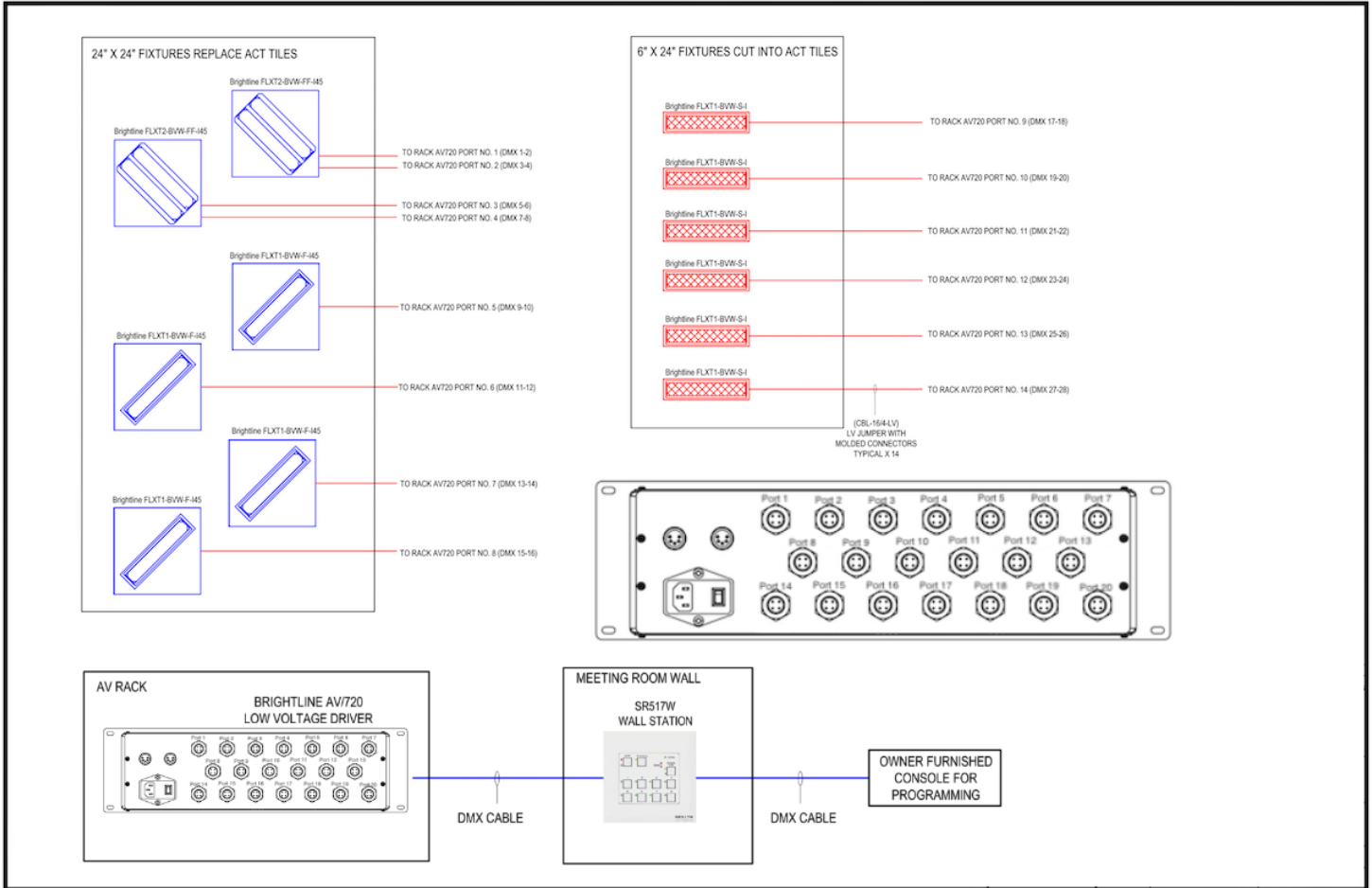

580 Mayer Street, Building #9, Bridgeville, PA 15017, USA

Brightlines.com | 1-412-206-0106



Installation Summary



- ▶ Mount AV/720 and connect to power.
- ▶ Install fixtures per the project layout. Visit the Brightline website under **Manuals** for more information on the installation of the fixture type being installed.
- ▶ Connect the cables according to the labels on each end.
- ▶ Install DMX source and wall panel, if required.
- ▶ Note: the maximum distance from the AV/720 to a fixture is 200'.

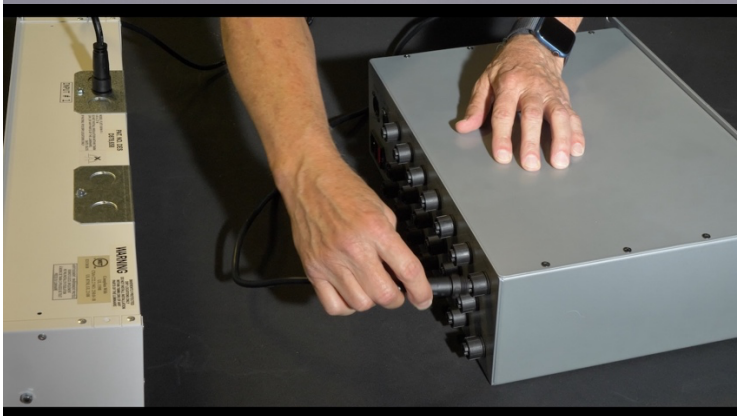

Connecting a Wall Station

The CTRL-WS-LV-SR517 wall station comes with all necessary parts to integrate into the stand-alone low-voltage control system. To connect the CTRL-WS-LV-SR517 to the AV/720 Power Driver, run the RJ45 to bare lead cable from the wall station to the DMX IN port on the back of the Power Driver, or to a DMX gateway networking device for integration with other controls. (see the [Brightline CTRL-WS-LV-SR517 Overview](#) for wiring instructions at the wall station). Ensure that the wall station is in line between the controller and the AV/720 Power Driver for proper operation. See the [Brightline CTRL-WS-LV-SR517 Overview](#) for more detail.

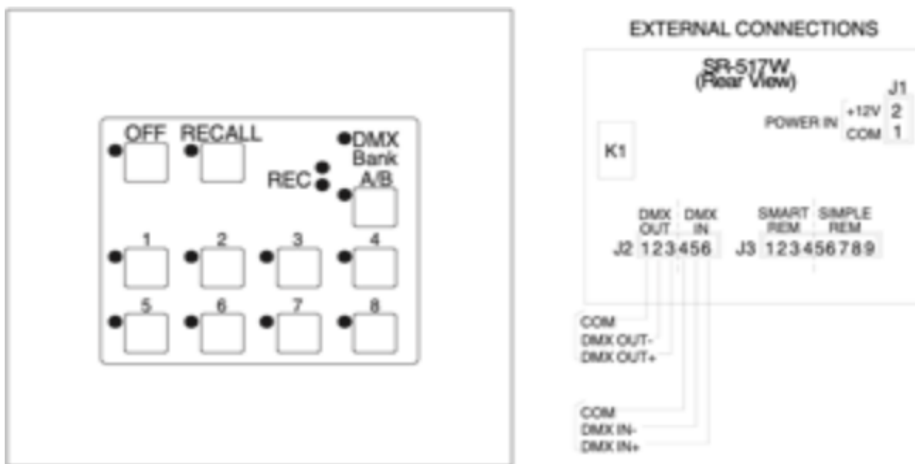

WARRANTY

Brightline guarantees the AV/720 to be free from defects in materials and workmanship for a period of **24 months** from the date of shipment.

PROCEDURES

If any product is found to be unsatisfactory under this warranty, the buyer must notify Brightline immediately. Once a course of action has been determined, if it is necessary to return the product to Brightline, a Return Authorization (RA) will be issued. **Ship the product directly to Brightline, 580 Mayer Street, Building #9, Bridgeville, PA 15017 USA.** The RA number should be marked on the shipping carton. The unit will be replaced or put into proper operating condition, free of all charges. The correction of any defects through repair or replacement by Brightline shall constitute fulfillment of all obligations and liability of Brightline to the buyer under this warranty and the contract of sale.

DISCLAIMERS

Brightline is not responsible for damage to its products caused by improper installation, maintenance, or use, by improper electrical hookups, or by unauthorized repairs.

Failure to notify **Brightline** of unsatisfactory operation or any improper or unauthorized installation, maintenance, use, repairs, or adjustments shall terminate the warranty and **Brightline** shall have no further responsibility under the warranty.

Brightline shall not be liable for special or consequential damages in any claim, action, suit, or proceeding arising under this warranty or contract of sale, nor shall **Brightline** be liable for claims for labor, loss of profits or goodwill, repairs, or other expenses incidental to replacement. **Brightline** makes no other warranty of any kind whatsoever, expressed, or implied, and all implied warranties of merchantability and fitness for a particular purpose that exceed the obligation specifically described in this warranty are hereby disclaimed by **Brightline** and excluded from this agreement.

All shipments, unless otherwise noted, are F.O.B. factory.

The customer is advised to inspect for shipping damage, apparent and/or hidden. If detected, notify the transportation company and file your claim.